

[PRINTED COPIES ARE UNCONTROLLED]



Queenstown Aerodrome Safety and Compliance Regulations

Copyright ©2008 by Queenstown Airport Corporation Ltd. Reproduction of this manual, or any part thereof is prohibited except with the approval from Queenstown Airport Corporation.

VERSION QASCR-3.2 EXP: 31/12/2025

QUEENSTOWN AERODROME SAFETY AND COMPLIANCE REGULATIONS

0 STATEMENT BY CHIEF OPERATING OFFICER

- 0.1.1 This manual has been prepared in part to satisfy Queenstown Airport Corporation's (QAC) obligations under Civil Aviation Rule 139. It is to be regarded as the Queenstown Aerodrome Safety and Compliance Regulations.
- 0.1.2 QAC, as the licensed aerodrome operator, must include in its regulatory suite of documents particulars for managing vehicles and people operating on Queenstown Airport Aerodrome or QAC-owned land. This document forms part of the Aerodrome Certification Exposition pursuant to Civil Aviation Rule Part 139.
- 0.1.3 These regulations have been developed as part of QAC's Safety Management System and endeavour to maintain a safe environment for protecting aircraft, aerodrome infrastructure, personnel, contractors, and members of the public.
- 0.1.4 It also contains details of essential operating procedures, rules, and regulations that may not be entirely safety-related but nevertheless are required to satisfy other legal, operational, and common law obligations.
- 0.1.5 QAC also has a general 'duty of care' under common law and obligations under Health and Safety legislation, Civil Aviation Rules, and the Civil Aviation Act concerning safety and security issues associated with operations undertaken at Queenstown Airport.
- 0.1.6 Failure to comply with the requirements of these regulations could be a breach of regulatory requirements and possibly an operator's right to use the airport facilities, and QAC will consider any such failure as to whether to exclude individuals or entities from accessing or operating at Queenstown Aerodrome or on QAC owned land.



Todd Grace
Chief Operating Officer
Queenstown Airport Corporation Ltd

QUEENSTOWN AIRPORT HEALTH, SAFETY AND SECURITY COMMITMENT POLICY

Queenstown Airport's vision is to achieve **Zero Harm** to those who visit and work within our airport community, including employees, contractors and visitors.

We are focused on developing a positive and collaborative Health, Safety and Security culture. A culture that is committed to playing a leadership role in promoting Health, Safety and Security across the airport and recognised as a benchmark for Health, Safety and Security excellence. An important part in achieving Zero Harm is ensuring that all our managers, employees and contractors clearly understand their responsibilities for Health, Safety and Security.

Queenstown Airport will:

- Take all practical and reasonable steps to provide and maintain a healthy, safe, secure and injury-free environment for employees, contractors and visitors
- Set high standards and expectations for Health, Safety and Security performance across the entire organisation
- Ensure engaged leadership and provide appropriate resources and processes to foster and support a culture of continuous improvement
- Engage with employees to allow them the opportunity to participate meaningfully in the development of a strong Health, Safety and Security culture
- Consult and work together with other organisations doing business at Queenstown Airport
- Measure, benchmark and regularly report on Health, Safety and Security performance
- Comply with all legislative requirements and industry standards

It is the responsibility of each manager and contractor manager to:

- Inspire an open, honest and supportive Health, Safety and Security culture through active participation and personal leadership
- Ensure employees are provided with adequate training and use safe work practices to carry out all tasks and activities
- Facilitate Health, Safety and Security meetings, reviews, audits and discussions where employees can confidently raise safety concerns, where they will be listened to and where their concerns will be addressed
- Identify, assess, eliminate or minimise risks to the personal Health, Safety and Security of employees and others in the workplace
- Support and facilitate the early, accurate and open reporting of near miss and injury events, including providing feedback and follow-up to employees
- Play an active role in the rehabilitation of any injured team member
- Through personal practice and leadership, ensure compliance with all Health, Safety and Security policies and procedures

It is the responsibility of all employees and contractors to:

- Demonstrate personal leadership by engaging in safe behaviour at all times and adhering to all procedures, rules and regulations relating to their work
- Adopt safe work practices that protect the Health, Safety and Security of themselves, other employees, contractors and visitors
- Report all near misses, accidents, injuries and Health, Safety and Security concerns promptly and accurately to an appropriate manager
- Actively participate in Health, Safety and Security meetings and discussions
- Participate in rehabilitation treatment to facilitate an early and sustainable return to work

Queenstown Airport regards the promotion of and adherence to this Policy as a priority for everyone who works at or has business at the airport. As such, this Policy applies to all Queenstown Airport employees, contractors and employees of contractors engaged to perform services on behalf of Queenstown Airport.

We appreciate your continued commitment to our Health, Safety and Security culture and performance.

2 RECORD OF AMENDMENT

2.1.1 The Queenstown Aerodrome Safety and Compliance Regulations are subject to change from time to time.

2.1.2 Distribution of these regulations is primarily electronic, through a secure online document management system accessible by authorised stakeholders on our SharePoint site. As information is updated, the revision number will be amended, and stakeholders will be notified of the changes via email.

REVISION	EFF. DATE	ACTIONED BY
Version 1.0	01 JUL 2009	QAC
Version 1.1	15 APR 2010	QAC
Version 1.2	01 AUG 2011	QAC
Version 1.3	04 APR 2013	QAC
Version 1.4	01 JAN 2015	QAC
Version 1.5	01 MAY 2019	QAC
Version 1.6	04 NOV 2019	Daniel Dodd – QAC (Creation of ASCR)
Version 1.7	13 OCT 2020	QAC
Version 1.8	01 JAN 2021	Daniel Dodd - QAC
Version 1.9	21 Apr 2021	Daniel Dodd - QAC
Version 2.0	14 Jun 2021	Daniel Dodd - QAC
Version 2.1	04 August 2021	Daniel Dodd - QAC
Version 2.2	01 January 2022	Daniel Dodd - QAC
Version 2.3	17 May 2022	Daniel Dodd - QAC
Version 3.0	1 January 2023	Daniel Dodd - QAC
Version 3.1	1 January 2024	Daniel Dodd - QAC
Version 3.2	1 January 2025	Daniel Dodd - QAC

3 TABLE OF CONTENTS

0	STATEMENT BY CHIEF OPERATING OFFICER.....	0-1
1	SAFETY AND SECURITY POLICY	1-1
2	RECORD OF AMENDMENT	2-2
3	TABLE OF CONTENTS	3-1
4	GENERAL	4-1
5	AVIATION SECURITY	5-1
6	BORDER SECURITY	6-1
7	GENERAL HEALTH AND SAFETY.....	7-1
8	AIRPORT PROXIMITY ACCESS CARDS	8-1
9	AIRSIDE VEHICLE PERMITS.....	9-5
10	AIRSIDE DRIVER PERMITS.....	10-1
11	APPROVED ISSUING AUTHORITIES	11-1
12	APPROVED TRAINING OFFICERS	12-1
13	ESSENTIAL SAFETY RULES & PROCEDURES	13-1
14	SAFETY AROUND AIRCRAFT	14-1
15	ACCIDENTS, INCIDENTS & EMERGENCIES	15-6
16	AERODROME MARKINGS & SIGNAGE	16-1
17	RADIO PROCEDURES	17-1
18	PENALTIES.....	18-1
19	MAPS AND CHARTS.....	19-1
20	DEFINITIONS	20-1

4.1 Legislative Requirements

- 4.1.1 On public roadways (landside), the provisions of New Zealand laws and regulations apply to vehicle registration and traffic movement. Queenstown Airport Corporation (QAC) controls vehicle airside at Queenstown Airport as part of its legal obligations under Civil Aviation Rule Part 139.
- 4.1.2 As the operator of an aerodrome certificated under the Civil Aviation Act 1990 and Civil Aviation Rule Part 139, QAC is to limit access of vehicles Airside to those necessary for aerodrome and aircraft operations. QAC is also required under Civil Aviation Rule Part 139 to ensure that each employee, tenant, or contractor who operates Airside at the aerodrome is familiar with and complies with these Queenstown Aerodrome Safety and Compliance Regulations.
- 4.1.3 QAC is obliged under the Health and Safety at Work Act 2015, to take all practicable steps to ensure that persons visiting or working at the airport are not exposed to harm, in addition to obligations for the safety of its employees, contractors and other workers.
- 4.1.4 Certain areas within Queenstown Airport are also subject to requirements under the Biosecurity Act 1993 and Customs and Excise Act 2018.
- 4.1.5 The principal aim of these regulations is to ensure that these obligations are met and that the risk of injury to persons and/or damage to property/aircraft is as low as is reasonably practicable.

4.2 Delegated Authorities

- 4.2.1 Under the authority of the Chief Executive, the QAC Head of Operations, Safety & Compliance is responsible for the overall administration of these regulations on behalf of QAC. Any reference in these regulations to the QAC Head of Operations, Safety & Compliance includes any employee of QAC to whom the Chief Executive has delegated authority to act on his or her behalf under the regulations (but, for the avoidance of doubt, the QAC Head of Operations, Safety & Compliance remains responsible for all matters under these regulations).
- 4.2.2 These regulations give QAC the authority to require persons Airside to produce specific documentation when requested.
- 4.2.3 Persons are required to:
- (a) Show their New Zealand Drivers' license, ADP (Airside Driver Permit) and AIC (Airport Identity Card) upon request by a QAC staff member, a QAC authorised person or an Officer of the Aviation Security Service.
- 4.2.4 Failure to comply may result in an Airport Infringement Notice (AIN) being issued to the person with a subsequent award of demerit points (which may lead to suspension or withdrawal of full or partial access to Queenstown Aerodrome, QAC-owned land or airport facilities).

4.3 Just Culture & Self-reporting

- 4.3.1 To encourage a culture of incident reporting, particularly self-reporting of safety-related incidents and accidents, QAC promotes a “no blame” culture. This approach is based on and supported by a Just Culture framework.
- 4.3.2 A strong safety culture is built on applying a Just Culture where open and honest reporting is supported and acknowledged. Specifically, Just Culture means a culture in which front-line operators or others (i.e., stakeholders, and QAC employees) are not punished for actions, omissions or decisions taken by them that are commensurate with their experience and training, but where gross negligence, wilful or repeated violations of these regulations and destructive acts are not tolerated.
- 4.3.3 The Just Culture framework strongly encourages self-reporting of safety-related incidents and accidents. QAC will factor in whether an individual has self-reported the incident or accident in determining the outcomes of an investigation.
- 4.3.4 For a self-report to be considered in determining the outcome of an investigation, it must:
- (a) Be reported via QAC’s online reporting tool (bit.ly/QACIncidentForm);
 - (b) Be reported within 24 hours of the incident occurring;
 - (c) Include the name and company of the individual self-reporting; and
 - (d) Include all relevant details the individual has relating to the incident or accident.

5 AVIATION SECURITY

5.1 Airport Identity Cards

- 5.1.1 An Airport Identity Card (AIC) is issued by the Aviation Security Service to identify who is authorised to be in a Security Area and/or Security Enhanced Area.
- 5.1.2 A valid AIC must be worn on the front of the outermost garment, at all times when an authorised person is in a Security Area and/or Security Enhanced Area.
- 5.1.3 An AIC holder must produce their AIC for inspection if requested by an authorised person.
- 5.1.4 An AIC holder must not lend their AIC to another person.
- 5.1.5 The AIC must be returned to the issuing authority when the need for its issue no longer exists.

5.2 Access Control

- 5.2.1 QAC prevents unauthorised access to restricted areas through swipe card access control. Individuals are assigned access on their AIC or QAC-issued access card.
- 5.2.2 An AIC holder must ensure that no other person(s) pass through an access-controlled door after they have swiped; except if:
 - (a) That person has also swiped, including PIN if required, and has been granted entry; or
 - (b) The AIC holder is escorting person(s) that are in possession of valid airport identification approved by the CAA and, in the case of escort required, will always remain with the escorted person(s) whilst in a Security Controlled area or Security Enhanced area.
 - (c) The AIC holder is escorting person(s) that are in possession of valid airport identification approved by the CAA without an escort required condition and has received approval to do so from QAC Operations. All escorted person(s) must have completed mandatory training required for the relevant area(s) ; or
 - (d) The AIC holder is escorting person(s) in an area that is not designated a Security Area or Security Enhanced area and has confirmed that escorting person(s) have completed all mandatory training required for the relevant area(s).; or
 - (e) Multiple persons are entering whilst inside a vehicle and the driver has ensured that all passengers have valid AICs and the appropriate Personal Protective Equipment (PPE).
- 5.2.3 The escorting AIC holder must keep all escorted person(s) updated on specific rules, including all relevant parts of these regulations while escorting. The escorting AIC

[PRINTED COPIES ARE UNCONTROLLED]

holder must also remain in control of the escorted person(s) so far as reasonably practicable to prevent a breach of these regulations.

- 5.2.4 Once an AIC holder has passed through an access-controlled door or security gate, they must ensure that it has been secured.
- 5.2.5 No access-controlled door or security gate may be left open or unlocked whilst unattended.
- 5.2.6 For Security and Security Enhanced roller doors on baggage belts, the last person using or overseeing baggage loading or unloading on the belt must ensure the roller doors on that baggage belt are closed and properly secured before leaving the area.
- 5.2.7 No person may open any access-controlled door through any other means than the access control system, unless prior approval from the Head of Operations, Safety & Compliance is given.

5.3 Unattended Items

- 5.3.1 No person may leave any bag(s) or item(s) unattended at the airport. This includes approved 'tools of the trade' taken into a Security Enhanced Area.
- 5.3.2 No person may look after a bag or item for someone you do not know.
- 5.3.3 Items must not be placed on or within 1.5 metres on either side of any fence, barrier, or other thing being used to prevent unauthorised access to any Security Area, Security Enhanced Area, or Operational Area.

5.4 Security and Security Enhanced Areas

- 5.4.1 Only approved persons may enter and remain in a Security Area or Security Enhanced Area.
- 5.4.2 Approved persons must hold and display on the front of their outer garment a valid AIC, and must only gain access to or remain in a Security Area or Security Enhanced Area for the purpose of their duties.

5.5 Departure Gate Lounges

- 5.5.1 All persons must pass through the BDF (Bulk Duty-Free) Screening to access the departure gate lounges. (Excluding gate 1).

5.6 Security Threats

- 5.6.1 No person may make inappropriate comments about security threats (bomb or hijack, etc.) at the airport.
- 5.6.2 No person may tamper with or cause damage to security equipment at the airport.

6.1 Biosecurity and Customs Controlled Areas

- 6.1.1 Only approved persons may enter and remain in a Biosecurity or Customs Controlled Area.
- 6.1.2 Approved persons must only access the Biosecurity or Customs Controlled Areas to undertake their Official Duties.
- 6.1.3 All persons (including authorised persons) in a Biosecurity or Customs Controlled Area may be asked about the purpose of their presence in the area. Biosecurity or Customs officer may examine any goods carried by persons into, or out of that area.
- 6.1.4 Food and drink must not be consumed inside a Biosecurity Controlled Area.

6.2 Removing items from a Biosecurity or Customs Controlled Area

- 6.2.1 Any items or risk goods removed from an international arriving aircraft, a Biosecurity Controlled Area or a Customs Controlled Area must be presented to a Customs Officer and a Biosecurity officer before being removed from the area.

6.3 International Waste

- 6.3.1 The Ministry for Primary Industries (MPI) provide Amnesty Bins for international arriving passengers to dispose of risk items. The Amnesty Bins are for passenger use only.
- 6.3.2 No items may be removed from the Amnesty Bins.
- 6.3.3 All international waste other than that disposed of by passengers directly into Amnesty Bins (per clause 6.3.1), shall be disposed of into a marked Biosecurity Waste Bin.
- 6.3.4 International waste from a Biosecurity Controlled Area or international aircraft must not be left on top of the Amnesty or Biosecurity Waste Bins, on the ground or in any other place outside of an Amnesty or Biosecurity Waste Bin.
- 6.3.5 All waste and risk goods disposed of in a Biosecurity Waste Bin must be double bagged.
- 6.3.6 The bin lid must be fully closed after the waste has been disposed of in a Biosecurity Waste Bin.

6.4 Devanning Bags

- 6.4.1 Baggage taken off an international arriving flight must be taken directly to the BCA for clearance by Customs and MPI once offloaded.

[PRINTED COPIES ARE UNCONTROLLED]

- 6.4.2 Before devanning bags onto the belt, the person must confirm that they are at the correct belt. A large screen at the entry to the baggage reclaim area and screens behind each belt display which belt should be used for each arriving flight.
- 6.4.3 Domestic bags should never be placed onto an international belt, as determined for the arriving flight, on the applicable display screen.
- 6.4.4 International bags should never be placed onto a domestic belt, as determined for the arriving flight, on the applicable display screen.
- 6.4.5 Devanning of bags from an air container (Unit Load Device, air can) from an international arriving flight must only occur under the supervision of an MPI-accredited person.
- 6.4.6 The MPI-accredited person must report to MPI any contaminants found using MPI's online reporting system. If the online reporting system is not operational, a back-up sheet is available behind Belt 2 to record the details. The accredited person must then log these details on the MPI online reporting system within 48 hours.

6.5 International Walkways

- 6.5.1 QAC staff and an airline staff member must ensure that the international arrivals walkway is set up and checked before disembarkation of an international flight in accordance with the International Apron Walkway Manual.
- 6.5.2 Airline staff must not allow passengers to disembark from an international flight before completing walkway checks and signing the international arrival checklist.
- 6.5.3 International arrival walkways should be set up so that passengers are taken directly into the Biosecurity Controlled Area for processing.
- 6.5.4 No staff member should make any physical contact with international arriving passengers for any reason other than work purposes.

6.6 International Arriving Aircraft

- 6.6.1 The operator of an international arriving aircraft must ensure that:
 - (a) The aircraft can leave New Zealand within 8 hours or;
 - (b) The aircraft can obtain clearance before it is a domestic aircraft to travel throughout New Zealand.
- 6.6.2 All aircraft that arrive in New Zealand must be disinfected and carry a valid certificate of disinfection in accordance with the Schedule of Aircraft Disinfection Procedures for flights into Australia and New Zealand.

6.7 Medical Events

- 6.7.1 In the case of a Medical Event on an international arriving flight, the following agencies must be notified:

[PRINTED COPIES ARE UNCONTROLLED]

- (a) Ambulance (if required);
- (b) Airport Emergency Services;
- (c) QAC;
- (d) Customs;
- (e) MPI, and
- (f) Aviation Security.

7 GENERAL HEALTH AND SAFETY

7.1 Personal Protective Equipment

7.1.1 High Visibility garments and enclosed shoes must be worn by all persons operating in all external areas and baggage halls airside, this includes aircraft movement areas and manoeuvring areas.

7.1.2 However, rule 7.1.1 does not apply to:

- (a) The pedestrian-only area directly behind the Airways control tower.
- (b) Pilot, crew or passengers boarding or de-boarding under escort by an AIC holder wearing the appropriate PPE.
- (c) Leased areas with approval from the leaseholder.

7.1.3 Safety shoes, hard hats, safety glasses, sunglasses and hearing protection should be worn in accordance with the policies as set by each person's employer. QAC recommends that all personnel wear approved hearing protection when working in noisy environments. However, all persons operating on movement areas or manoeuvring areas must always have immediate access to hearing protection.

7.1.4 The High-Visibility Garments worn must, at minimum, meet the standards in AS/NZS 4602:2011 and PAS 10:2001.

7.2 Smoking

7.2.1 No person can smoke anywhere or anytime while airside at Queenstown Airport. This includes smoking inside vehicles or buildings that are Airside.

7.2.2 No person is permitted to smoke anywhere landside other than in a designated smoking area.

7.2.3 In this clause, **smoke/smoking** includes having a lit cigarette or other thing that can be smoked.

7.3 FOD Control Measures

7.3.1 It is the responsibility of all persons operating Airside at Queenstown Airport to reduce Foreign Object Debris (FOD) by removing any item of FOD encountered whilst Airside and placing it in the clearly marked FOD receptacles located around the apron.

[PRINTED COPIES ARE UNCONTROLLED]



- 7.3.2 Drivers must ensure when operating vehicles carrying loose material (such as garbage, plastic sheeting, paper, and gravel) that the load is adequately secured or covered to prevent spillage. Any item that falls from a vehicle must be recovered by the driver and secured to prevent further spillage and possible FOD damage to aircraft.
- 7.3.3 Any significant FOD items, such as aircraft components and large objects, should be reported immediately to Queenstown Airport Emergency Services on 03 450 9058 for subsequent logging and investigation.
- 7.3.4 Items blowing onto any airport movement areas must be immediately brought to the attention of Queenstown Airport Emergency Services on 03 450 9058.

7.4 Portable Electronic Devices

- 7.4.1 Portable electronic devices such as mobile telephones and radio devices may only be used airside when their use is required to allow an individual to conduct their Official Duties.
- 7.4.2 Persons using their portable electronic devices under clause 7.4.1 may not use the device within 6 meters of aircraft fuel, fuelling points, fuel vents, or fuelling equipment unless the portable electronic device has been designed or certified to an industry standard for use in fuelling areas.

7.5 Animals Airside

- 7.5.1 All animals (e.g., Dogs, etc) must be restrained inside an appropriate container or cage before entering airside. Once airside, animals are not to be released from their cages or containers.
- 7.5.2 Permission will not be granted to any person to take an animal Airside, even though they may be restrained on a leash. Animals in landside areas should also be restrained to prevent them from gaining Airside access.
- 7.5.3 Police & Border Control Agencies are exempt from this rule. However, animals used by these agencies must always be restrained when Airside.

7.6 High Winds

- 7.6.1 High wind conditions can give rise to hazards from wind-blown items and in very strong winds there is a possibility of structural damage to aircraft. The principal threats are for engine ingestion or airframe damage to aircraft. There is also a danger of personal injury to passengers and airside personnel and damage to vehicles and equipment.
- 7.6.2 A weather warning system at Queenstown Airport provides the Operations team, Airways, and airlines with automated advice on wind and severe weather conditions at Queenstown Airport and the surrounding area. The system notifies relevant parties by text of any wind conditions over 25kts.
- 7.6.3 When a high wind warning has been issued, the following actions must be taken by airlines, handling agents, operators, and personnel:
- (a) Extra vigilance must be exercised to prevent accumulations of FOD to ensure that all loose items are removed or safely stowed (plastic bags and sheeting are a particular threat to engine ingestion in all airport areas). Action must be taken to ensure that covers are securely fastened on all waste containers.
 - (b) All ground equipment and vehicles on the aprons, not in immediate use, must be parked in the areas provided with parking brakes applied.
 - (c) Equipment used on aprons must be secured with parking brakes set. Equipment without parking brakes must be chocked or removed.
 - (d) Large items of equipment that are vulnerable to winds, such as empty ULD's, must be secured to a fixed object or removed to a protected area.
 - (e) All loose items in works areas must be secured or removed.
 - (f) Any personnel observing any obstruction or equipment moving in the wind, irrespective of ownership, must take action to secure it, or advise QAC.
- 7.6.4 Aircraft operators are responsible for issuing instructions limiting operations when wind speeds exceed aircraft and towing limits.
- 7.6.5 All airside operators must ensure that all their equipment is stored to prevent it from moving at any time while not in use.

7.7 Drugs & Alcohol

- 7.7.1 A zero-tolerance policy on drug and alcohol use at Queenstown Airport is strictly enforced. No person is permitted to commence or remain on duty when they are intoxicated or under the influence of any illegal or prohibited substance.
- 7.7.2 Alcohol consumption by any personnel during meal breaks or while on duty is strictly prohibited.
- 7.7.3 Persons unsure of the effects of using prescription or non-prescription drugs and medication should seek medical advice and discuss the matter with their employer.

7.8 Bicycles, Tricycles, Unicycles & Skateboards

- 7.8.1 No person is to ride or store a bicycle, tricycle, unicycle, skateboard, or similar device Airside without the written permission of the QAC Head of Operations, Safety & Compliance. Riders may however dismount and walk with their bicycle Airside.
- 7.8.2 The QAC Head of Operations, Safety & Compliance may approve the use of pushbikes and may impose conditions to suit the requirement of the operation. However, pushbikes are prohibited in the Manoeuvring Area.
- 7.8.3 Any approval given by the QAC Head of Operations, Safety & Compliance may be withdrawn at any time.

7.9 Pedestrian & Passenger Safety

- 7.9.1 Passengers moving to and from aircraft must not be directed to pass under the fuselage or wings, or close to any propellers or rotors of any aircraft. Care must also be taken to ensure passengers are not exposed to jet blast, engine ingestion or prop wash hazards.
- 7.9.2 Aircraft operators or their handling agents must ensure their passengers are supervised when on the apron. Minimum supervision is one person at the terminal building entry/exit point and a second person at the aircraft. Where the access from the aircraft is not in a direct line to or from the terminal building, additional personnel must be positioned to supervise and guide passengers.
- 7.9.3 Passengers are not permitted to depart the terminal building until the aircraft they are due to board has come to a complete stop, the aircraft engines have been shut down, and the anti-collision lights have been switched off.
- 7.9.4 Pedestrian access across the Movement Area is prohibited unless such access is required for staff to undertake their Official Duties (i.e., Headset operator). Other persons requiring access around the apron area must follow the marked walkways.
- 7.9.5 Only designated crossing points may be used when crossing roads.

7.10 Behaviour

- 7.10.1 No person may act in an aggressive or threatening manner.
- 7.10.2 No person may cause physical harm to any person(s)

8 AIRPORT PROXIMITY ACCESS CARDS

8.1 Introduction

8.1.1 QAC issues approved staff with Airport Proximity Access Cards in order to gain access to access-controlled areas of the airport. The access authorised by QAC is separate to the issue of AICs by Avsec. Whilst in an access-controlled area an access card holder must be able to produce their Airport Proximity Access Card on request from an authorised person.

8.1.2 For the purposes of these regulations, Airport Proximity Access Cards include:

- (a) the technology included in valid AICs (such as those issued by Avsec) that allows QAC to restrict access fully or partially to the airport, until the date of expiry of that AIC; and
- (b) separate physical cards, issued by QAC, that allow QAC to restrict access fully or partially to the airport.

8.1.3 For the avoidance of doubt:

- (a) before the expiry of the AIC that includes the Airport Proximity Access Card of the type set out in clause 8.1.2(a), holders will need to apply for a new AIC from Avsec, in addition to a new Airport Proximity Access Card of the type set out in clause 8.1.2(b).
- (b) holders of an Airport Proximity Access Card of the type set out in clause 8.1.2(b) will be required to carry a valid Airport Proximity Access Card in addition to an AIC always issued by Avsec while airside.

8.2 Application

8.2.1 All relevant forms and criteria are available from the Airport Information Desk.

8.3 Criteria for Issue

8.3.1 The applicant for an Airport Proximity Access Card must be employed or contracted by an approved organisation and be able to provide evidence that access is required for the purpose of their employment (or contractual) duties.

8.3.2 This evidence may include an Airport Identity Card (AIC), Authority to Work Permit (ATWP) or other evidence that QAC deems acceptable.

8.4 Surrender of an Airport Proximity Access Card

8.4.1 When access to access-controlled areas is no longer required, the access card holder must advise QAC Operations immediately and return their Airport Proximity Access Card to QAC within 72 hours after the cessation of duties.

8.5 Demerit Points

- 8.5.1 QAC has a penalties system for breaches of these regulations. Details of the penalties system and the Demerit Points which apply to each offence are set out in Part 18.
- 8.5.2 Any person who accumulates 12 or more Demerit Points during any 36-month period may have their Airport Proximity Access Card suspended or withdrawn in accordance with these regulations.
- 8.5.3 The Demerit Points system does not restrict the general discretion of QAC to suspend or withdraw an Airport Proximity Access Card in accordance with these regulations.

8.6 Suspension of an Airport Proximity Access Card

- 8.6.1 QAC may at any time suspend the operation of an Airport Proximity Access Card, where the holder has accumulated 12 or more Demerit Points during any 36-month period or has been involved in, or alleged to have been involved in a serious safety, security or compliance breach.
- 8.6.2 If QAC suspends the operation of an Airport Proximity Access Card, it may be done immediately following oral or written notice to the Airport Proximity Access Card holder or their employer. The notice will specify the:
 - (a) Reason/s for, and
 - (b) The period of the suspension.
- 8.6.3 If oral notice is given in the first instance, the QAC Head of Operations, Safety & Compliance will issue a written notice within 72 hours of the oral notice.
- 8.6.4 Within 72 hours of receipt of a notice of suspension of an access card, the holder must surrender the access card to QAC, if the card is of the type identified in clause 8.1.2(b).
- 8.6.5 Employers and/or government agencies may also request via email that QAC suspend the operation of an employee's Airport Proximity Access Card by providing QAC with sufficient reasons why the suspension should occur. However, the decision to suspend the operation of the Airport Proximity Access Card remains at QAC's discretion. Such a suspension could be for the purposes of an investigation or may be for any other reason, provided QAC accepts that such reason justifies suspension.
- 8.6.6 At any time during the period of Airport Proximity Access Card suspension, the QAC Head of Operations, Safety & Compliance may:
 - (a) Lift the suspension.
 - (b) Extend the period of suspension.
 - (c) Invite the Airport Proximity Access Card holder, to explain in writing why the access should not be withdrawn.
 - (d) withdraw the Airport Proximity Access Card per clause 8.7.

8.7 Withdrawal of an Airport Proximity Access Card

- 8.7.1 At any time during a suspension period, the QAC Head of Operations, Safety & Compliance may withdraw an Airport Proximity Access Card by oral and/or written notice to the Airport Proximity Access Cardholder or their employer. That notice will specify the reason/s for the withdrawal. If oral notice is given in the first instance, the QAC Head of Operations, Safety & Compliance will issue written notice within 72 hours of the oral notice.
- 8.7.2 Within 72 hours of receipt of an oral or written notice of withdrawal of an Airport Proximity Access Card, the holder must surrender the Airport Proximity Access Card to QAC, if the access card is of the type identified in clause 8.1.2(b) and the holder has not already surrendered the access card in accordance with a suspension.
- 8.7.3 Following the suspension of an Airport Proximity Access Card, the QAC Head of Operations, Safety & Compliance must invite the Airport Proximity Access Card holder, in writing, to explain why the access card should be reinstated. The holder should write to the QAC Head of Operations, Safety & Compliance, within 7 days, stating the reasons for reinstatement of the Airport Proximity Access Card.
- 8.7.4 If no explanation has been received from the Airport Proximity Access Cardholder within 7 days, the access card shall remain suspended without further correspondence. If an explanation is received within 7 days, QAC shall consider that explanation. If QAC is not satisfied with the explanation provided, it shall have the discretion to decide that the Airport Proximity Access Card should be withdrawn.
- 8.7.5 Any airport users may request the withdrawal of an employee's Airport Proximity Access Card by providing the QAC Head of Operations, Safety & Compliance with sufficient reasons as to why withdrawal should occur.
- 8.7.6 QAC may decide to reinstate the Airport Proximity Access Card to the holder, at its discretion.

8.8 Appeal of Decisions – Airport Proximity Access Cards

- 8.8.1 An appeal can be made in relation to:
- (a) The award of demerit points (refer to Part 18); or
 - (b) The withdrawal of an access card.
- 8.8.2 Appeals will be heard by an independent third party, appointed by QAC. The party will fully review the decision, considering all available evidence.
- 8.8.3 Appeals against the award of Demerit Points may be made to the QAC Head of Operations, Safety & Compliance, in writing, within 7 days from the date of the Demerit Point being imposed, and/or notice of the access card being withdrawn. The

[PRINTED COPIES ARE UNCONTROLLED]

appeal is to be addressed to the QAC Head of Operations, Safety & Compliance in the first instance. QAC reserves the right to refuse any appeal not made within the 7-day period.

- 8.8.4 The QAC Head of Operations, Safety & Compliance will contact an independent third party within 7 days of receiving the appeal.
- 8.8.5 Any Demerit Points given at the time of the incident, and/or any access card withdrawal will stand until such a time as the independent third party determines otherwise.

9.1 Introduction

9.1.1 An Airside Vehicle Permit (AVP) is an authority issued by QAC allowing the operation of a vehicle on the Airside areas of Queenstown Airport. No person may drive a vehicle airside, that is not authorised by an AVP unless it is under vehicle escort as described in these regulations. The provisions contained within these regulations control the access and operation of the vehicle(s) on Airside areas of the Airport.

9.1.2 The issue of an AVP does not entitle a Vehicle Operator to parking space on Airside areas at Queenstown Airport or to access Airside areas where such access is not necessary for work purposes. A person cannot operate a vehicle with an AVP unless that person has a valid ADP or is under escort by a suitably authorised person as defined in these regulations.

9.2 Vehicles in Leased Areas

9.2.1 An AVP is not required for Vehicles used SOLELY within leased areas, unless the lessee requires that an AVP be issued.

9.3 Application

9.3.1 All relevant forms and criteria for an AVP application are available from The Hub (QAC Operations Centre).

9.3.2 Applications must be submitted no less than 14 days before any anticipated need for the AVP.

9.3.3 The QAC AVP application form must be accompanied by the following documents:

- (a) either of the following:
 - I. Certificate of Registration; or
 - II. A letter of compliance from a qualified mechanic that the vehicle complies with the relevant standards.
- (b) Evidence of both, public liability and vehicle 3rd party insurance of no less than as mentioned in 9.5 of this manual.
- (c) A covering letter from the applicant, explaining the need for the vehicle to have Airside access.
- (d) If applicable, a letter from the 'contracting company', sponsoring the access.
- (e) Photos showing the front, rear and both sides of the vehicle(s).

9.3.4 An AVP may be issued for up to one year. AVPs may only be issued for longer periods in exceptional circumstances.

[PRINTED COPIES ARE UNCONTROLLED]

9.3.5 In considering any “contract for service” arrangements, applicants should not anticipate automatic AVP approval.

9.4 Criteria for Issue

9.4.1 The major criteria for the issue or renewal of an AVP for a particular vehicle, is that the applicant must demonstrate an operational need to drive that vehicle Airside on a frequent and unescorted basis. The applicant must further show that the operational task(s) cannot otherwise be undertaken landside.

9.4.2 In addition, in deciding whether to issue an AVP, the following will be considered:

- (a) Safety Airside in relation to aviation operations, persons, and property.
- (b) The security of aircraft and other property located Airside.
- (c) Congestion of airside areas, thereby decreasing the efficiency of the airport (particularly movement areas) and increasing the risk of accidents to airport users.
- (d) The ability of the Vehicle Operator to ensure that the operation of the vehicle is in compliance with the requirements of these regulations and with all laws, rules, standards and directions including, where applicable, legislative requirements and Air Traffic Control directions, relating to the operation of vehicles Airside.
- (e) Notwithstanding (d) above, that there are appropriate arrangements in place to ensure that if the vehicle becomes immobilised in a Movement Area, it will be removed without delay.
- (f) Whether appropriate arrangements are in place to ensure that if the vehicle becomes immobilised in a Movement Area, the notification required under clause 15.3 will be given.
- (g) The vehicle will be maintained in a state of good repair.

9.4.3 In addition, the applicant must, meet one or more of the following criteria:

- (a) Be directly involved with the operation or servicing of aircraft at Queenstown Airport (including refuelling).
- (b) Be directly involved with the servicing of Ground Service Equipment (GSE) at Queenstown Airport.
- (c) Be directly involved with servicing or maintaining airside facilities, equipment, buildings, or other facilities that cannot be reached via a Landside alternative.
- (d) Be directly involved with servicing other equipment that can only be reached via an Airside route.
- (e) Be a member of a government organisation (Customs, MPI, AVSEC, Police) with a demonstrated need to drive a vehicle Airside on a frequent and unescorted basis.

[PRINTED COPIES ARE UNCONTROLLED]

- (f) Be directly involved with the servicing of air navigation equipment.
- (g) Have a need to transport/relocate equipment Airside on a frequent basis.
- (h) Have a need to be Airside on a frequent and unescorted basis, e.g., maintenance contract (supported by documentation from the sponsor including details of the frequency of entry onto Queenstown Airport, and areas to which access is required).
- (i) Carry out regulatory or law enforcement activities.
- (j) Any other purpose approved in writing by the QAC Head of Operations, Safety & Compliance.

9.5 Insurance

- 9.5.1 The vehicle operator must provide proof of vehicle third-party and public liability insurance, which clearly shows the inclusion of airside cover for each vehicle seeking an AVP. The amount of the public liability and vehicle third-party insurance coverage must be no less than:
- a) NZD \$10 million public liability, and
 - b) NZD \$10 million vehicle third party

9.6 Roadworthiness/Vehicle Condition

- 9.6.1 Where appropriate, QAC will use the New Zealand warrant/certificate of fitness standards as set by New Zealand Transport Agency (NZTA). At the time of application for an AVP, vehicle operators must submit a copy of the vehicle's current registration details (if applicable).
- 9.6.2 Any vehicle not subject to holding a certificate of registration under New Zealand laws will be required to submit a letter from a qualified mechanic, confirming that the vehicle is in a good state of repair, having regard to the nature of the vehicle and its functions.
- 9.6.3 The QAC reserves the right to conduct or order a serviceability inspection on any vehicle that appears not to be in a good state of repair at any time.
- 9.6.4 A vehicle serviceability check may include (but not be limited to) the following:
- (a) Towing attachments.
 - (b) Tyre condition.
 - (c) Body condition.
 - (d) Excess emissions.
 - (e) Seat belts (if fitted).

[PRINTED COPIES ARE UNCONTROLLED]

- (f) All vehicle lights.
- (g) Horn (if fitted).
- (h) Fluid leaks.

9.6.5 **IATA Specification** – Where appropriate, in the case of specialist Airport Vehicles, QAC may use the vehicle standards as set by the International Air Transport Association (IATA) to determine whether a vehicle is in a good state of repair.

9.6.6 **Non-Specific** – In the case of a specialist airport Vehicle, where no NZTA or IATA specification exists, the QAC may give approval for the use of such a vehicle in accordance with certain limitations or restrictions, which QAC may attach to the AVP at the time of issue, or subsequently attach as a condition of continued operation.

9.6.7 Any vehicle not meeting the standards of serviceability as set down in either NZTA, IATA or otherwise by the QAC, will have the AVP suspended, and the Vehicle Operator must remove the vehicle from Airside and return the AVP to QAC within 24 hours.

9.6.8 The AVP may be reissued once repairs have been completed and QAC has received written verification from a qualified mechanic to that effect.

9.7 New Types of Vehicles

9.7.1 Where a Vehicle Operator plans to acquire a new type of vehicle for airport use, they must advise QAC of the proposal, allowing a minimum of 14 days for an assessment to be made about compatibility with pavements and the local geography of the airport.

9.7.2 The information necessary to make such an assessment for the proposed vehicle will ordinarily include:

- (a) Make & Model.
- (b) Compliance with NZTA or IATA standards (where applicable).
- (c) Dimensions.
- (d) Gross mass.
- (e) Number, spacing and size of wheels, types of tyres and their pressures.
- (f) Turning radius.
- (g) Motive power.
- (h) Areas of intended operations.
- (i) Safety & special features.

9.7.3 To avoid any doubt, the QAC retains absolute discretion about whether or on what condition to issue or renew an AVP.

[PRINTED COPIES ARE UNCONTROLLED]

9.8 Issue of an AVP

- 9.8.1 The QAC Head of Operations, Safety & Compliance is authorised by QAC to issue AVP.
- 9.8.2 Upon receipt of an AVP application, the QAC Head of Operations, Safety & Compliance will consider the application and assess whether the issue of an AVP is appropriate.
- 9.8.3 Upon approval, QAC will notify the Vehicle Operator that the AVP label is ready for collection.
- 9.8.4 Upon issue of the AVP label, it must be affixed to the front windscreen of the vehicle.
- 9.8.5 Where the vehicle does not have a windscreen, the AVP label is to be affixed to be clearly visible on the front of the vehicle.
- 9.8.6 Holding an AVP for a vehicle does not automatically give that vehicle or its passengers the right to enter Airside.

9.9 Removal of Vehicles from Airside

- 9.9.1 If a vehicle is being driven, is stopped or parked Airside in a manner that is likely to endanger a person or property (including other vehicles or aircraft) or is likely to interfere with the operation of the Airport, the QAC Head of Operations, Safety & Compliance, or authorised officers, may direct the driver to remove it from Airside.
- 9.9.2 Refusal to comply with such a request is an offence, and penalties may apply.
- 9.9.3 If the driver of the vehicle cannot be found, or refuses to comply with the direction, the QAC Head of Operations, Safety & Compliance, or authorised officers may direct that the vehicle be moved to a place within the Airport approved for that purpose.
- 9.9.4 The Vehicle Operator will be required to pay all costs incurred by QAC for the removal of the vehicle.

9.10 Suspension of an AVP

- 9.10.1 Subject to these regulations, an AVP is valid until the expiry date shown on the AVP label.
- 9.10.2 The QAC Head of Operations, Safety & Compliance's authority to suspend or withdraw is not limited only to situations where there is a breach of these regulations. In some circumstances, the QAC Head of Operations, Safety & Compliance may consider it appropriate to suspend, cancel, or limit the number of vehicles or operators at the Airport for general congestion, operational efficiencies, emissions, safety, or security.
- 9.10.3 QAC may at any time suspend an AVP pending for the purposes of further investigation, where QAC has reason to believe that:

[PRINTED COPIES ARE UNCONTROLLED]

- (a) The vehicle or Vehicle Operator does not meet the requirements of clauses 9.4 - 9.6; or
- (b) there has been a breach of these regulations that is sufficiently serious to consider withdrawing the AVP.

9.10.4 Suspension of an AVP under clause 9.10.3 maybe done with immediate effect by oral and written notice to the Vehicle Operator. Notification will specify the:

- (a) Reason/s for; and
- (b) Period of, the suspension.

9.10.5 Within 72 hours of receipt of a notice of suspension, the Vehicle Operator must either:

- (a) Physically surrender the AVP to the QAC; or
- (b) If the AVP cannot be removed from the Vehicle, destroy the AVP and provide QAC with a statutory declaration that the AVP has been destroyed.

9.10.6 At any time during a period of suspension under these regulations, QAC may, by written notice to the Vehicle Operator:

- (a) Re-issue the AVP for the balance of its term (and any applicable AVP issue charges may apply); or
- (b) Extend the period of suspension; or
- (c) Invite the Vehicle operator to explain in writing why the AVP should not be withdrawn; or
- (d) withdraw the AVP in accordance with clause 9.11.

9.10.7 The Vehicle Operator should write to the QAC Head of Operations, Safety & Compliance, within 7 days, explaining their case for reinstatement of the AVP. Failure to respond to such a request will result in the immediate withdrawal of the AVP. No form of credit or refund will be available because of that withdrawal.

9.11 Withdrawal of an AVP

9.11.1 At any time during a suspension period, QAC may withdraw an AVP by oral and/or written notice to the Vehicle Operator. That notice will specify the reason/s for the withdrawal. If oral notice is given in the first instance, QAC will issue written notice within 72 hours of the oral notice.

9.11.2 Following the suspension of an AVP, QAC must invite the Vehicle Operator, in writing, to explain why the AVP should be reinstated. The Vehicle Operator should write to the QAC Head of Operations, Safety & Compliance, within 7 days, stating the case for reinstatement of the AVP.

9.11.3 If no explanation has been received from the Vehicle Operator within 7 days, the AVP shall remain suspended without further correspondence. If an explanation is received within 7 days, QAC shall consider that explanation. If QAC is not satisfied with the

[PRINTED COPIES ARE UNCONTROLLED]

explanation provided, it shall have the discretion to decide that the AVP should be withdrawn.

- 9.11.4 Any airport users may request QAC withdraw an AVP by providing QAC with sufficient reasons as to why withdrawal should occur. The decision to withdraw the AVP remains with QAC.
- 9.11.5 In deciding whether to withdraw an AVP, the criteria for issuing an AVP as detailed in clause 9.3 may be used. Notification of an AVP withdrawal will be made in writing to the Vehicle Operator as soon as practicable.
- 9.11.6 If QAC decides that the AVP should be reinstated, and the AVP has already been surrendered in accordance with the suspension, QAC must either return the original AVP to the Vehicle Operator or reissue an AVP if QAC has received a statutory declaration from the Vehicle Operator that the AVP has been destroyed.

9.12 Appeal of Decisions – AVP

- 9.12.1 An appeal can be made in relation to:
 - (a) The award of demerit points (refer to Part 18); or
 - (b) The withdrawal of an AVP; or
 - (c) A decision to downgrade an AVP.
- 9.12.2 Appeals will be heard by an independent third party, appointed by QAC, who will fully review the decision, considering all available evidence to make an independent decision. If required a third party 'specialist' may be called in to act as an advisor.
- 9.12.3 Appeals may be made to the QAC Head of Operations, Safety & Compliance, in writing, within 7 days from the date of the Demerit Point being imposed and/or notice of the decision to withdraw/downgrade the AVP being received. The appeal is to be addressed to the QAC Head of Operations, Safety & Compliance in the first instance. QAC reserves the right to refuse any appeal not made within the 7-day period.
- 9.12.4 The QAC Head of Operations, Safety & Compliance will contact the independent third party within 7-days of receiving the appeal.
- 9.12.5 Any Demerit Points given at the time of the incident, and/or any amendments to an AVP, will stand until such time as the independent third party determines otherwise.

9.13 Renewal of an AVP

- 9.13.1 Every application for renewal of an AVP is reviewed on a case-by-case basis. The holding of a current AVP is not sufficient grounds for an automatic renewal of the AVP for that vehicle, or for any other vehicle.

[PRINTED COPIES ARE UNCONTROLLED]

9.13.2 At the time of renewal, the Vehicle Operator must satisfy QAC that the criteria set out for the issue of an AVP (as stated at clauses 9.4 - 9.65 above) continue to be met.

9.14 Renewal Application

9.14.1 All relevant forms and criteria for application are available from The Hub (QAC Operations Centre).

9.14.2 Applications must be submitted to airsidepermits@queenstownairport.co.nz no less than 14 days before the expiry if the Vehicle Operator wishes to continue to use the vehicle Airside.

9.14.3 The QAC AVP Application form must be accompanied by the following documents in support of the application.

- (a) Certificate of Registration of the Vehicle for use on public roads.
- (b) Evidence of public liability insurance of not less than as stated in 9.5 of this manual.
- (c) A cover letter from the applicant confirming the continued need for Airside access for the vehicle.
- (d) If applicable, a letter from the 'contracting' company, sponsoring continued access.

9.15 Temporary AVP

9.15.1 The QAC Head of Operations, Safety & Compliance may, if deemed necessary, issue a temporary AVP in accordance with provisions of an approved Method of Works Plan (MOWP) or other temporary works programme.

9.15.2 A Vehicle Operator must, when applying for a temporary AVP submit all relevant documentation as in the case of any permanent AVP application.

9.15.3 A Vehicle Operator must when applying for a temporary AVP, submit any additional documentation requested by the QAC Head of Operations, Safety & Compliance in support of the application.

9.16 Expiry of an AVP

9.16.1 When an AVP expires, the Vehicle Operator must either:

- (a) Physically return the AVP to QAC; or
- (b) If the AVP cannot be removed from the Vehicle, destroy the AVP and provide QAC with a statutory declaration that the AVP has been destroyed.

9.17 Disposal of Vehicle with an AVP

9.17.1 When a Vehicle Operator disposes of a vehicle that has an AVP, prior to disposal, the Vehicle Operator must either:

[PRINTED COPIES ARE UNCONTROLLED]

- (a) Within 7 days of disposal, physically return the AVP to QAC; or
- (a) If the AVP cannot be removed from the vehicle, destroy the AVP and provide QAC with a statutory declaration that the AVP has been destroyed.

9.17.2 QAC should be notified of the disposal of any vehicle within 72 hours.

10 AIRSIDE DRIVER PERMITS

10.1 Introduction

- 10.1.1 An Airside Driver Permit (ADP) is a privilege issued by QAC that permits the holder of the ADP to operate a vehicle on the Airside at Queenstown Airport within certain designated areas, depending upon the Category of the ADP the driver holds (as set out below).
- 10.1.2 QAC is responsible for issuing ADPs, which may be delegated to approved vehicle operators. Refer to Part 11 of these regulations for further information.

10.2 Categories of ADP

- 10.2.1 The Airside areas for which driving is authorised for each Category of ADP are:
- (a) Category 1: Southern General Aviation Area only.
 - (b) Category 2: Southern General Aviation Area and main apron.
 - (c) Category 3: All areas.
- 10.2.2 A map illustrating these areas is contained in Part [19](#) of these regulations.

10.3 Endorsement to an ADP

- 10.3.1 Specific endorsements may be developed when and if warranted e.g. N- Night, D – Day, L – Limited.

10.4 Eligibility to hold an ADP

- 10.4.1 An applicant must demonstrate a proper and reasonable need for an ADP and should not assume that there is a right to drive Airside. The applicant must demonstrate that there is an operational requirement for the unescorted operation of an Airside vehicle before QAC issues an ADP.
- 10.4.2 In the case of an applicant who has not held an ADP in the same or higher Category for the Airport, the QAC or Approved Issuing Authority (as the case may be) may only issue the ADP if satisfied that the applicant:
- (a) Has an operational requirement to drive unescorted Airside on a frequent basis.
 - (b) Holds a current New Zealand Driver's License or international equivalent.
 - (c) Is familiar with the Airport geography and comprehends the terminology used to describe Airside.
 - (d) Understands the significance of these regulations.

[PRINTED COPIES ARE UNCONTROLLED]

- (e) If applying for a Cat 3 ADP, holds a Flight Radio Operators Certificate or equivalent for Queenstown Airport.
- (f) If applying for a Cat 3 ADP, has a thorough knowledge of Air Traffic Control instructions, apron operational restrictions and safety issues associated with Airside.

10.5 QAC ADP Theory Tests

- 10.5.1 Applicants for all Categories of ADP are required to pass QAC's written theory test.
- 10.5.2 Applicants must correctly answer 100% of the QAC written assessment questions to complete the theory test successfully. At the time of assessment, applicants failing to answer any questions correctly may immediately attempt the test again. Should they be unsuccessful in correctly answering these questions a second time, they may attempt the test a third time. A fourth attempt at the test may only be undertaken after a mandatory study/training period of not less than 72 hours.
- 10.5.3 The theory test aims to ensure that the applicant has knowledge applicable to driving safely Airside. Questions are drawn from these regulations.
- 10.5.4 Applicants for Category 3 ADPs must also pass a practical assessment that may be up to one (1) hour in duration (or as dictated by the testing officer).

10.6 Application for an ADP

- 10.6.1 In deciding whether to issue an ADP, the following must be considered:
 - (a) The demonstrated operational requirement for unescorted driving access on a frequent basis (i.e., at least weekly).
 - (b) The overall safety of Airside, having regards to the number of and functions of persons and property Airside.
 - (c) The security Airside, and aircraft on it.
 - (d) The efficient utilisation of the Airside facilities.
- 10.6.2 To avoid any doubt, the QAC Head of Operations, Safety & Compliance retains absolute discretion whether, or under what conditions, to issue or renew an ADP.

10.7 Prerequisites for issue of Category 1 or Category 2 ADP

- 10.7.1 For Cat 1 ADP, the applicant must:
 - (a) Complete a minimum of eight (8) hours driving. A substantial part of this time must be as a driver under supervision.
 - (b) Demonstrate to an Approved Training Officer the ability to:
 - I. Safely operate the vehicle in the vicinity of aircraft.
 - II. Correctly Give way to aircraft taxiing or under tow.

[PRINTED COPIES ARE UNCONTROLLED]

- III. Recognise aircraft which have anti-collision lights on and their main engines running.
 - IV. Pass behind aircraft with their main engines in operation; having awareness of the dangers of jet blast and safe distances to pass.
 - V. Minimum distance for the operation of vehicles from parked or taxiing aircraft.
- (c) Demonstrate knowledge of:
- I. Safety procedures concerning passengers moving about on Aprons, to and from aircraft.
 - II. Geographic limits for Cat 1 ADP drivers and recognition of the boundaries of Manoeuvring Areas, by day and night.
 - III. Compliance with speed limits and signage as appropriate, and observance of safe speeds for existing conditions.
 - IV. Correct procedures for live taxiway crossings.
 - V. Knowledge of relevant airside safety policies such as “No Seat, No Ride”, and other safety matters as specified in Part 13 of these regulations.

10.7.2 For a Cat 2 ADP, the applicant must:

- (a) Complete a minimum of twenty (20) hours driving. A substantial part of this time must be as a driver under supervision; and
- (b) Demonstrate to an Approved Training Officer the ability to:
 - I. Safely operate the vehicle in the vicinity of aircraft.
 - II. Correctly Give way to aircraft taxiing or under tow.
 - III. Recognise aircraft with anti-collision lights on and their main engines running.
 - IV. Pass behind aircraft with their main engines in operation; having awareness of the dangers of jet blast and safe distances to pass.
 - V. Minimum distance for the operation of vehicles from parked or taxiing aircraft.
- (c) Demonstrate knowledge of:
 - I. Safety procedures with passengers moving about on Aprons, to and from aircraft.
 - II. Geographic limits for Cat 1 and Cat 2 ADP drivers and recognition of the boundaries of Manoeuvring Areas, by day and night.

[PRINTED COPIES ARE UNCONTROLLED]

- III. Compliance with speed limits and signage as appropriate, and observance of safe speeds for existing conditions.
- IV. Knowledge of parking areas, equipment storage areas and equipment staging areas and their associated markings.
- V. Correct procedures for live taxiway crossings.
- VI. Knowledge of relevant airside safety policies such as “No Seat, No Ride”, and other safety matters as specified in Part 13 of these regulations.

10.8 Prerequisites to application for Category 3 ADP

10.8.1 For Cat 3 ADP's, the applicant must:

- (a) Completed a minimum of forty (40) hours driving. A substantial part of this time must be as a driver under supervision on the Manoeuvring Area.
- (b) Be able to demonstrate to a QAC Approved Training Officer competence in operating a vehicle on the Manoeuvring Area that will include the following:
 - I. All of the matters required to be demonstrated by an applicant for a Cat 1 or Cat 2 ADP, as set out in clause 10.7 above.
 - II. Recognition & meaning of Movement Area Guidance Signs (MAGS) to determine physical location on the airfield.
 - III. Recognition & meaning of all day & night markers & markings, e.g., MAGS, taxiway intersection markings, holding points, runways and all lighting.
 - IV. Correct procedures for entering or crossing live taxiways, runways and runway strips.
 - V. Correct radio procedures and use of standard phraseology.
 - VI. Knowledge of radio failure procedures and light signals from ATC.

10.8.2 An applicant for a Cat 3 ADP who currently holds a current Cat 2 ADP may reduce the hours of training required for the Cat 3 ADP, by taking into consideration the time logged in training for a Cat 2 ADP. For example, a driver upgrading from a Cat 2 ADP, needs to complete an additional twenty (20) hours driving.

10.9 Issue – Cat 1 or Cat 2 ADP

10.9.1 The QAC Head of Operations, Safety & Compliance or an Approved Issuing Authority may issue an ADP only after the applicant:

- (a) Satisfies the eligibility requirements as certified by and Approved Training Officer.
- (b) Provides evidence of an approved Airport Identity Card.

[PRINTED COPIES ARE UNCONTROLLED]

- (c) Provides evidence of a current New Zealand Driver License or international equivalent with a certified English translation if not in English.
- (d) Successfully completes the QAC theory test.

10.10 Issue – Cat 3 ADP

10.10.1 The QAC Head of Operations, Safety & Compliance may issue an ADP only after the applicant:

- (a) Satisfies the eligibility requirements as certified by and Approved Training Officer.
- (b) Provides evidence of a current approved Airport Identity Card.
- (c) Provides evidence of a current New Zealand Driver License or international equivalent with a certified English translation if not in English.
- (d) Understand radio procedures and use of standard phraseology.
- (e) Successfully completes the QAC theory test.
- (f) Successfully completes a practical driving assessment with an Approved Training Officer.

10.11 Conditions of Issue

10.11.1 An ADP will be valid for 24 calendar months from the day of issue (unless otherwise specified by the QAC Head of Operations, Safety & Compliance), or until suspended or withdrawn by QAC.

10.11.2 If an ADP holder ceases to be employed by a Vehicle Operator, and is subsequently reemployed by the same employer, provided the period between employment is less than two months, the ADP may be re-issued with the same expiry date and without the need to follow the initial application procedure. In all other scenarios where a vehicle operator is hired for work by another employer at Queenstown Airport, the driver must re-apply/apply for a new ADP following the full application process.

10.11.3 The ADP is valid only while the ADP holder is in possession of a current New Zealand Driver's License or international equivalent. If, for whatever reason, an ADP Driver's License has been cancelled or suspended:

- (a) The ADP holder must immediately advise QAC or the relevant Approved Issuing Authority of this fact; and
- (b) The ADP will be immediately suspended for the period of the cancellation/suspension of that Driver's License.

10.12 ADPs and Penalties

10.12.1 QAC has a penalties system for breaches of these regulations. Details of the penalties system and the Demerit Points which apply to each offence are set out in Part 18.

[PRINTED COPIES ARE UNCONTROLLED]

- 10.12.2 If a Vehicle breaches these regulations but QAC cannot identify the driver of the Vehicle at the time of the offence, then QAC may allocate the points to the Vehicle Operator who is the principal applicant for AVPs.
- 10.12.3 The system does not restrict the general discretion of QAC to suspend an ADP in accordance with these regulations.
- 10.12.4 Any person, who accumulates 12 or more Demerit Points for airside driving offences during a 36-month period, will immediately have their ADP suspended until the total demerit points accumulated returns to beow 12 (subject to QAC's discretion to shorten the suspension period, or withdraw the ADP, in accordance with these regulations).

10.13 Renewal of an ADP

- 10.13.1 An applicant may renew an ADP at any time up to one month before the expiry date of that ADP.
- 10.13.2 To renew an ADP, applicants must:
- (a) Submit an application form signed by a recognised signatory of the applicant's employer.
 - (b) Demonstrate that there continues to be an operational requirement for frequent unescorted access to the Airside.
 - (c) Provide evidence of a current approved Airport Identity Card.
 - (d) Provide evidence of a current New Zealand Drivers License or international equivalent.
 - (e) Successfully complete the QAC theory test.
 - (f) For Cat 3 applicants, successfully complete a practical driving assessment with an Approved Training Officer.
- 10.13.3 QAC or an Approved Issuing Authority may re-issue an ADP to applicants if these requirements and eligibility criteria are satisfied.
- 10.13.4 The applicant's airside driving record, including any demerit points issued from all previously issued ADPs, still applies as a driver's record and demerit points are held on the driver's personal record and not on the ADP.

10.14 Upgrading an ADP

- 10.14.1 A driver may apply to upgrade an ADP from Cat 1 to Cat 2 or Cat 2 to a Cat 3.
- 10.14.2 In applying to upgrade an ADP, an applicant must:
- (a) Establish a genuine need to upgrade the ADP.
 - (b) Satisfy the eligibility requirements for that category of ADP as listed in the preceding clauses.

[PRINTED COPIES ARE UNCONTROLLED]

10.14.3 The Issuing Authority is under no obligation to upgrade the ADP, and each application must be established on a case-by-case basis.

10.15 Downgrading of an ADP

10.15.1 The holder of an ADP that no longer meets the prerequisites of that category of the ADP is obliged to downgrade the ADP to an appropriate category. The circumstances under which this will happen are set out in clause 10.15.3.

10.15.2 The ADP holder must present the ADP for re-issue, either to QAC or to the Authorised Issuing Authority, within 72 hours of the stated downgrade taking effect.

10.15.3 The QAC Head of Operations, Safety & Compliance may downgrade the category of any ADP under the following circumstances;

- (a) The ADP holder is subject to investigation.
- (b) The ADP holder's category has been lowered due to the award of demerit points.
- (c) The ADP holder is unable to substantiate the need to maintain the category of the ADP.

10.16 Surrender of an ADP

10.16.1 When a driver is no longer required by their employer to drive Airside, the ADP holder must advise QAC Operations immediately and must return the ADP to the Approved Issuing Authority or QAC within 72 hours of the cessation of driving duties. The Vehicle Operator must also ensure that the ADP holder complies with this clause.

10.16.2 The ADP is not transferable between individuals or Vehicle Operators and is issued for use at Queenstown Airport only.

10.17 Suspension of an ADP

10.17.1 The QAC may at any time suspend an ADP (whether issued by QAC or an Approved Issuing Authority), for the purposes of further investigation, where an ADP holder is involved in, or alleged to have been involved in:

- (a) An air safety incident.
- (b) A vehicular or other accident at Queenstown Airport.
- (c) A serious breach of these regulations.

10.17.2 Any person, who accumulates 12 or more points during a 36-month period, will immediately have their ADP suspended, for six months. The final suspension period will be determined by the QAC Head of Operations, Safety & Compliance, following the outcome of any investigation conducted by QAC.

[PRINTED COPIES ARE UNCONTROLLED]

- 10.17.3 If QAC suspends an ADP under clause 10.17.1, it may be done with immediate effect by oral or written notice to the ADP holder or their employer. The notice will specify the:
- (a) Reason/s for, and
 - (b) The period of the suspension.
- 10.17.4 If oral notice is given in the first instance, the QAC Head of Operations, Safety & Compliance will issue a written notice within 72 hours of the oral notice.
- 10.17.5 Within 72 hours of receipt of an initial notice of suspension of an ADP, the holder must immediately surrender the ADP to QAC.
- 10.17.6 Vehicle Operators may also request QAC to suspend an employee's ADP by providing QAC with sufficient written advice as to why the suspension should occur. However, the decision to suspend the Airport Proximity Access Card remains at the discretion of QAC.
- 10.17.7 At any time during the period of ADP suspension, the QAC Head of Operations, Safety & Compliance may:
- (a) Lift the suspension.
 - (b) Extend the period of suspension.
 - (c) Downgrade the category of the ADP.
 - (d) Invite the holder of the ADP, to explain in writing why the ADP should not be withdrawn (refer also to clauses 10.18 and clause 10.19).
 - (e) withdraw the ADP per clause 10.18.
- 10.17.8 Following a suspension of an ADP, the ADP holder must reapply for an ADP as a new ADP holder and at the discretion of the QAC Head of Operations, Safety & Compliance, a practical test before their ADP can be reinstated.

10.18 Withdrawal of an ADP

- 10.18.1 At any time during a suspension period, the QAC Head of Operations, Safety & Compliance may withdraw an ADP (whether issued by QAC or an Approved Issuing Authority) by oral and/or written notice to the ADP holder and the Vehicle Operator. That notice will specify the reason/s for the withdrawal. If oral notice is given in the first instance, the QAC Head of Operations, Safety & Compliance will issue written notice within 72 hours of the oral notice.
- 10.18.2 Within 72 hours of receipt of the initial notice of withdrawal of an ADP, the ADP holder must immediately surrender the ADP to QAC, if they have not already done so in accordance with a suspension.
- 10.18.3 Following the suspension of an ADP, QAC may invite the holder, in writing, to explain why the ADP should not be withdrawn. The holder should write to QAC, within 7 days, stating the case for reinstatement of the ADP.

[PRINTED COPIES ARE UNCONTROLLED]

- 10.18.4 If no explanation has been received from the holder within 7 days, the ADP shall remain withdrawn without further correspondence. If an explanation is received within 7 days, QAC shall consider that explanation. If QAC is not satisfied with the explanation provided, it shall have the discretion to decide that the ADP remains withdrawn.
- 10.18.5 Any airport users may request QAC to withdraw an employee's ADP by providing the QAC Head of Operations, Safety & Compliance with sufficient written advice as to why withdrawal should occur. However, the decision to withdraw the ADP remains at the discretion of QAC.
- 10.18.6 QAC may, at its discretion, reinstate the ADP for the holder, provided the holder successfully completes the theory test, and the practical test (if QAC has determined that such tests are required).

10.19 Appeals

- 10.19.1 An appeal can be made about:
- (a) The award of demerit points (refer to Part 18); or
 - (b) The withdrawal of an ADP; or
 - (c) A decision to downgrade an ADP.
- 10.19.2 Appeals will be heard by an independent third party, appointed by QAC, who will fully review the decision considering all available evidence to make an independent decision.
- 10.19.3 Appeals may be made to the QAC Head of Operations, Safety & Compliance in writing, within 7 days from the date of the Demerit Point being imposed and/or notice of a change in the status of an ADP. The appeal is to be addressed to the QAC Head of Operations, Safety & Compliance in the first instance. QAC reserves the right to refuse any appeal not made within the 7-day period.
- 10.19.4 The QAC Head of Operations, Safety & Compliance will contact the independent third party within 7 days of receiving the appeal.
- 10.19.5 Any Demerit Points given at the time of the incident and/or any amendments to the status of an ADP, will stand until such time as the independent third party determines otherwise.

11 APPROVED ISSUING AUTHORITIES

11.1 Introduction

- 11.1.1 An Approved Issuing Authority (AIA) is a company or organisation in which QAC has delegated the responsibility of carrying out the training, testing, and issuance of ADPs for Queenstown Airport.
- 11.1.2 The QAC Head of Operations, Safety & Compliance may authorise an Approved Issuing Authority who can then issue ADPs to their own employees. Any authorisation will be subject to the conditions set out in these regulations, and any other reasonable conditions imposed by the QAC. For example, it is a condition of any authorisation that an AIA may only issue an ADP in approved categories and in accordance with the criteria set out in these regulations.
- 11.1.3 When applying to be an Approved Issuing Authority, the company or organisation must provide QAC with the following information:
- (a) The number of employees likely to be issued with ADPs.
 - (b) A copy of the proposed training material, which must include:
 - I. Rules for Driving Airside
 - II. Geography of the Airport
 - III. ATC Radio procedures
 - IV. Airport Layout, Markings and Signage
 - V. Standard company airside operating procedures
 - (c) Trading name of any Subsidiary company to which they intend to issue ADPs.

11.2 Information to Drivers

- 11.2.1 An AIA must keep an up-to-date register/database of ADPs issued, and the following (as amended by QAC from time to time):
- (a) Application forms for ADPs
 - (b) All current documents, forms, training and testing material.
- 11.2.2 The QAC will ensure that all AIAs receive the following material to distribute/make available to its employees:
- (a) These regulations (and amendments as issued)
 - (b) Safety Notices
 - (c) Security Notices

[PRINTED COPIES ARE UNCONTROLLED]

- (d) Advisory Circulars
- (e) Application form for ADPs
- (f) Any other documents, forms, training and testing material available.

11.3 Record Keeping/Audit

11.3.1 An AIA must:

- (a) Retain all ADP applications for a minimum of 12 months after cessation of an ADP holders employment.
- (b) Make and retain for a minimum of 2 years, records sufficient to enable QAC from time to time to conduct an audit to ensure the AIA is maintaining satisfactory standards in the carrying out of its functions, including a record of:
 - I. The assessment on behalf of the AIA of the compliance of ADP applicants with the requirement of these regulations.
 - II. The materials use in the training and testing of applicants for ADPs/Approved Training Officers.
 - III. The training and testing of individual applicants for ADPs/Approved Training Officers.
 - IV. A log of practical training time for individual applicants for ADPs/Approved Training Officers.
- (c) Provide QAC with reasonable access to its records and premises to enable the conduct of audits to ensure that the AIA is maintaining satisfactory standards in the carrying out of its function as an AIA; and
- (d) Ensure that relevant officers and employees of the AIA and its subsidiaries make themselves available and cooperate with QAC when conducting such audits.

11.3.2 The AIA must train and test its employees and the employees of its subsidiaries to drive airside to the standard required by these regulations and any additional requirements as stated in the approval.

11.4 Cancellation

11.4.1 The QAC Head of Operations, Safety & Compliance may at any time revoke the authorisation of an AIA by giving 7 days' written notice to the AIA.

11.4.2 A vehicle operator may appeal a decision to revoke an authorisation of an AIA to QAC. Appeals may be made in writing to the QAC Head of Operations, Safety & Compliance. The QAC Head of Operations, Safety & Compliance will arrange for a member of QAC's SLT (Senior Leadership Team) to review the appeal.

[PRINTED COPIES ARE UNCONTROLLED]

- 11.4.3 If the cancellation is the result of multiple safety or compliance breaches or the outcome of a non-compliant audit, the QAC Head of Operations, Safety & Compliance may require all existing ADPs issued through the AIA to be suspended or withdrawn. Any drivers still requiring an ADP will need to reapply for an ADP.

12 APPROVED TRAINING OFFICERS

12.1 Introduction

12.1.1 An Approved Training Officer is a person who is accepted by the QAC Head of Operations, Safety & Compliance as able to deliver training to persons wishing to obtain an ADP.

12.2 Nominated Training Officer

12.2.1 An Approved Issuing Authority may at any time submit in writing to the QAC Head of Operations, Safety & Compliance a nomination for a person to be an Approved Training Officer, where that person:

- (a) Holds a current ADP at the level that he/she seeks approval to train.
- (b) Has held an ADP in that category for more than 12 months.
- (c) Has no driving offences in the last 12 months.
- (d) Drives frequently (more than once a week) in that category.

12.2.2 The QAC Head of Operations, Safety & Compliance may approve the nominated person to be an Approved Training Officer subject to limitations and conditions set as the QAC Head of Operations, Safety & Compliance considers appropriate, and those conditions will be set out in a Letter of Authority.

12.2.3 The QAC Head of Operations, Safety & Compliance may, before issuing any Letter of Authority, require that persons nominated to be Approved Training Officers undergo an assessment to confirm their suitability for such tasks.

12.3 Scope of Authority

12.3.1 An Approved Training Officer may only train and test for categories of ADP as specified by QAC in a Letter of Authority.

12.3.2 Approved Training Officers are required to train and test the employees of the Approved Issuing Authority who apply for an ADP.

12.3.3 Approved Training Officers must monitor driving performance and undertake continuous improvement to the training content or process as necessary.

12.4 Testing of Approved Training Officers

12.4.1 Approved Training Officers must make themselves available for assessment by the QAC Head of Operations, Safety & Compliance on request.

[PRINTED COPIES ARE UNCONTROLLED]

12.5 Suspension of Authority

12.5.1 The QAC Head of Operations, Safety & Compliance may at any time suspend a person's approval as an Approved Training Officer. A written notice will be given within 7 days of the suspension, and will specify the:

- (a) Reason/s for; and
- (b) Period of the suspension.

12.6 Cancellation of Authority

12.6.1 At any time during a suspension period, the QAC Head of Operations, Safety & Compliance may cancel the approval of a person as an Approved Training Officer by giving 7 days written notice to the Approved Training Officer, or the Approved Issuing Authority (as the case may be).

13 ESSENTIAL SAFETY RULES & PROCEDURES

13.1 Introduction

- 13.1.1 These Essential Safety Rules & Procedures are an important part of the system that QAC has put in place to promote the safe and orderly movement of staff, passengers, aircraft, and vehicular traffic Airside.
- 13.1.2 Failure to comply with these rules & procedures may constitute an offence under these regulations.
- 13.1.3 Any failure to comply with the requirements of these rules will also be considered by the QAC in deciding whether to suspend or withdraw a person's ADP or other privileges.
- 13.1.4 Operators may develop procedures that enhance safety Airside; however, they must not contradict these regulations.

13.2 Basic Driving Rules

- 13.2.1 A person driving a vehicle Airside, including a person driving a Vehicle under supervision (escorted), must always comply with these regulations.
- 13.2.2 The QAC Head of Operations, Safety & Compliance authorises the use of vehicles Airside through the issuance of AVPs and ADPs, but maintains authority to control access to its property, regardless of the validity of the documents issued.
- 13.2.3 Drivers must not drive a Vehicle Airside unless they carry a current New Zealand Driver License, or other driving license recognised and compliant with New Zealand Transport Agency regulations and meet all requirements in Part 10.
- 13.2.4 When driving Airside, drivers must:
 - (a) Understand the regulations and restrictions that apply to Airside areas.
 - (b) Be familiar with the designations & geographic layout of the runways and taxiways; and comply with the radio procedures.
 - (c) Not drive in a manner likely to jeopardise the safety of any person, property or equipment.
 - (d) Obey all signage, pavement markings, and traffic control devices. Where roadways intersect and there are no signs or markings, New Zealand Road rules apply.

13.3 Safe driving

- 13.3.1 Drivers must not drive in a manner deemed to be careless or inconsiderate by QAC or:
 - (a) Drive a vehicle, or cause a vehicle to be driven, carelessly or without reasonable consideration for other persons.

[PRINTED COPIES ARE UNCONTROLLED]

- (b) Drive a motor vehicle or cause a motor vehicle to be driven recklessly.
- (c) Drive a vehicle, or cause a motor vehicle to be driven, at speed or in a way, having regard to all the circumstances, is or might be dangerous to the public or to a person.

13.3.2 Drivers must not cut across aircraft parking stands. Only the apron service road should be used to travel across the apron.

13.4 Portable Electronic Devices

13.4.1 A driver must not operate a vehicle airside while answering or using a hand-held mobile telephone.

13.5 Driving Around Pedestrians & Passengers

13.5.1 Vehicles must not be driven through passengers moving to or from an aircraft. Passenger walkway lines are provided on the apron to delineate passenger routes to and from aircraft. These lines consist of a solid blue or yellow pathway with white cross bars and borders. Vehicles must give way to pedestrians using a passenger walkway. In the event of a terminal evacuation vehicles must give way to all pedestrians.

13.5.2 Vehicles entering the baggage handling areas from the apron have the right of way. Pedestrians must give way to vehicles in these areas.

13.6 Leased Areas

13.6.1 No person or vehicle may enter a leased area airside without the approval of the lessee unless they have a regulatory requirement to enter that area (QAC vehicles and personnel excepted).

13.7 The driver of a vehicle operating within a leased area must comply with the procedures for control of vehicles within that area produced by the lessee and approved by the QAC.

13.8 Unserviceable Areas

13.8.1 No person or vehicle may enter an area delineated by unserviceability markers and markings and/or lighting unless there is an operational need. If necessary to enter the area, the driver must exercise extreme caution and only remain in that area for the period of that operational need.

13.9 Vehicle Entry Airside

13.9.1 All vehicles entering Airside at Queenstown Airport must comply with the following conditions:

- (a) Be in a state of good repair.
- (b) Must display a company name or logo of the registered owner of the vehicle.

[PRINTED COPIES ARE UNCONTROLLED]

- (c) Must have an operating amber rotating lighting beacon affixed to the uppermost part of the body of the vehicle or if under escort display amber flashing lights visible 360 degrees around the vehicle (i.e. Hazard Lights).
- (d) Vehicle drivers must adhere to security regulations and have a lawful reason or excuse to be in any airside area.

13.9.2 Those vehicles operating on the manoeuvring area must carry a current airport map and ATC light signals label – as approved by QAC.

13.9.3 For safety and security reasons, any vehicle may be subject to inspection and/or search by a QAC Operations Officer, Aviation Security Service Officer, an Officer of the New Zealand Police or other authorised person prior to entry Airside.

13.9.4 A vehicle may be refused entry at any time based on, but not limited to any of the following conditions:

- (a) Heightened Security
- (b) Aerodrome Emergency
- (c) Low Visibility Operations
- (d) FOD Risk
- (e) Vehicle Defect
- (f) As otherwise directed by the QAC Head of Operations, Safety & Compliance

13.10 No Seat, No Ride Rule

13.10.1 No person shall ride on or operate a vehicle when the passenger number is in excess of the designated capacity of that vehicle i.e., **NO SEAT, NO RIDE.**

13.10.2 In the case of a vehicle being classified as a 'Bus', the number of 'standing' passengers must not be more than the designated capacity of that vehicle.

13.10.3 The wearing of seatbelts is required in vehicles where seat belts are fitted.

13.11 Speed Limits

13.11.1 When driving airside at the Airport, drivers must observe the following speed limits:

- | | | |
|--|---|-----------|
| (a) Baggage Make-up & Reclaim Halls | - | 8 km/hr. |
| (b) Within 15m of an aircraft (unless on apron road) | - | 8 km/hr. |
| (c) Aircraft Parking Aprons & Apron Road | - | 30 km/hr. |
| (d) General Aviation Area (Category 1 Area) | - | 30 km/hr. |
| (e) Aircraft manoeuvring area (Category 3 Area) | - | 60 km/hr. |

[PRINTED COPIES ARE UNCONTROLLED]

- 13.11.2 Where a speed limit is indicated by a sign or pavement marking, this speed limit supersedes the limits specified in 13.11.1.
- 13.11.3 Where there is an operational requirement for speeds greater than those indicated above, approval must be sought from the QAC Head of Operations, Safety & Compliance, and the vehicle must be always driven in a safe manner. In general, approval to vary the above speeds is only given to drivers involved in Airport emergency or Airport Inspections, or under the direction of ATC.
- 13.11.4 The speed limits are not indicators of the speed in which driver should operate vehicles, they indicate the maximum permitted speed. In all cases, the driver must operate the vehicle at a safe speed suitable for the conditions (below the maximum permitted).

13.12 Rules of the Road

- 13.12.1 All aircraft, including those being towed, have the right of way over all other vehicles.
- 13.12.2 Vehicles travelling on Airside roadways have the right of way over vehicles entering/crossing roadways.
- 13.12.3 The following conditions apply to any vehicle overtaking another vehicle Airside:
- (a) The overtaking vehicle must not breach the safe speed limit for that area.
 - (b) The overtaking manoeuvre must be conducted in a safe manner.
 - (c) The overtaking manoeuvre must not force any other vehicle off its intended path.
 - (d) The overtaking manoeuvre must not force any other vehicle onto any part of the manoeuvring area (i.e. Runways).

13.13 Towing Rules

- 13.13.1 Drivers must not operate with a train of rolling stock more than:
- (a) Six (6) on aprons and airside roads; or
 - (b) As stipulated under local arrangements within the baggage handling areas. Drivers involved in towing rolling stock should refer to their company's SOP regarding the number that can be towed safely by their company equipment (which may be less than the maximum number set out in the preceding rule).
- 13.13.2 Drivers towing Air Stairs must comply with the 5m clearance to stationary aircraft except under the following conditions:
- (a) Docking to aircraft

13.14 Operating in the Manoeuvring Area

- 13.14.1 A driver must not enter the Manoeuvring area unless:

[PRINTED COPIES ARE UNCONTROLLED]

- (a) There is an operational requirement to do so.
- (b) A Category 3 ADP is held (except tugs pushing back aircraft).
- (c) A specific clearance is obtained to enter and operate in the manoeuvring area.
- (d) The company name or logo must be displayed on both sides of the vehicle and be clearly readable from at least 100 meters.
- (e) The vehicle displays (on top of the vehicle) an operating rotating beacon that is red and/or blue for emergency response vehicles and amber for other vehicles, or if under escort, displays amber flashing lights visible 360 degrees around the vehicle (i.e. Hazard Lights).
- (f) Between sunset and sunrise or in conditions of declared low visibility, the Vehicle has headlights illuminated (dipped) and taillights operating;
- (g) The vehicle (or aircraft for pushback) is equipped with a radio capable of receiving and transmitting on Queenstown Tower frequencies.
- (h) Whilst operating in the Manoeuvring area the driver must monitor the Queenstown Tower frequency and give way to all aircraft movements.

13.14.2 In the case of aircraft tugs with aircraft attached, clearances should be communicated through the flight crew.

13.14.3 Tugs without aircraft attached will need to be escorted by a vehicle capable of receiving and transmitting on the Queenstown Tower frequencies.

13.14.4 In all cases, clearance from ATC must be obtained prior to commencing the tow or entering the Manoeuvring Area.

13.15 Vehicle Defects

13.15.1 Drivers must:

- (a) Notify the vehicle operator of any vehicle defect as soon as they become aware of it.
- (b) Immediately draw to the attention of the vehicle operator any written statement purporting to have been issued by or on behalf of the QAC Head of Operations, Safety & Compliance or notice of a defect in a vehicle.

13.16 Unpaved/Grassed Areas

13.16.1 Travel across or onto unpaved or un-grassed areas, unless expressly directed by ATC, is not to be undertaken because:

- (a) Airside drainage may not be readily discernible.
- (b) Drains are not marked.

[PRINTED COPIES ARE UNCONTROLLED]

- (c) Minimum topsoil on the grassed areas.
- (d) Mud, gravel and grass would be tracked when returning onto the paved areas, creating a FOD hazard for aircraft.
- (e) Having a vehicle disabled or bogged within the Taxiway or Runway strips could create aircraft surface movement problems.

13.16.2 Contractors and approved personnel undertaking work Airside that requires vehicles to be operated on unpaved areas will be required to have equipment and resources ready to clean their vehicles and/or to undertake sweeping and cleaning of aircraft pavements that are crossed.

13.17 Vehicle & Equipment Parking

13.17.1 Vehicles or equipment must not be parked so that they will obstruct aircraft, other vehicles, pedestrians or any access doors from terminals or airport buildings.

13.17.2 All aircraft servicing equipment, when not in use must be stored in marked equipment storage areas or other storage areas designated by QAC.

13.17.3 All aircraft servicing equipment awaiting immediate use is to be staged entirely within marked equipment staging areas on aircraft hardstands.

13.17.4 Vehicles containing potentially hazardous material such as fuel tanker vehicles must be stored in designated areas only. Fuel tankers must not be stored adjacent to any terminal building or other publicly accessible zones.

13.17.5 Fuel tanker vehicles/dispensers are not permitted to park unattended within **15 meters** of any building.

13.17.6 Vehicles must not be parked or left in areas designated by signs or otherwise clearly marked as no parking areas. Under the regulations, failure to observe no parking areas is an offence, and QAC may:

- (a) Serve infringement notices on the driver or the owner of the vehicle for breaches of these airside regulations, which will result in demerit points; or
- (b) Alternatively, QAC may commence court proceedings for these offences.

[PRINTED COPIES ARE UNCONTROLLED]

13.18 Vehicle Escorts

- 13.18.1 Drivers of vehicles not authorised to drive airside (i.e. drivers without an ADP) may precede airside only if they are in possession of a valid Airport Identity Card or Temporary Airport Identity Card and under the supervision of an escort. QAC or a vehicle operator may make available a suitably authorised person to act as an escort.
- 13.18.2 For the purposes of this rule, a suitably authorised person is a holder of a Valid Airport Identity Card and Airside Drivers Permit:
- (a) Of the category required for the escort; and
 - (b) With at least six (6) months in that category.
- 13.18.3 A driver holding an appropriate ADP for the area of operation may escort an aircraft/vehicle in one of the following ways:
- (a) Driving a vehicle for which an AVP is current and appropriately equipped to escort the supervised vehicle; or
 - (b) Supervising by riding in the aircraft/vehicle; or
 - (c) Accompanying the supervised aircraft/vehicle on foot.
- 13.18.4 Before a driver of a vehicle commences escorting an aircraft/vehicle, the driver of the escort vehicle must ensure that the driver of the supervised aircraft/vehicle is aware of the following requirements:
- (a) Any specific rules for driving airside applicable to the proposed route.
 - (b) How the escort will be conducted.
 - (c) The proposed route.
 - (d) To closely follow the vehicle (no greater than 10m).
 - (e) To always give way to aircraft and passengers on aprons.
 - (f) To keep the supervised vehicle behind the escorting vehicle at a distance that will always ensure adequate supervision.
- 13.18.5 If the driver of the escorting vehicle is unsure of the correct procedures at any time, they must contact ATC immediately if they are within the manoeuvring area or QAC Airport Emergency Services in any other scenario.
- 13.18.6 The maximum number of vehicles that may be escorted at one time is two (2). For large semi-trailers or large non-articulated vehicles, the maximum is one (1).
- 13.18.7 Any convoy greater than that stated in clause 13.18.6 must have written approval from the QAC Head of Operations, Safety & Compliance.

[PRINTED COPIES ARE UNCONTROLLED]

- 13.18.8 The QAC Head of Operations, Safety & Compliance may withdraw at any time consent for a driver to act as an escort. This will be done by written notice to the driver and will be a new condition of the ADP issued to that driver.

14 SAFETY AROUND AIRCRAFT

14.1 Introduction

- 14.1.1 Queenstown Airport serves a wide range of aircraft types. The aircraft range from large jet aircraft, such as the Airbus A321, to small propeller-driven aeroplanes and helicopters.
- 14.1.2 Numerous hazards exist to both personnel and aircraft when the two operate in the same Airside environment. Each type of aircraft brings its own unique hazards to this environment, and the rules contained in this section are to ensure that all personnel operate safely around aircraft.
- 14.1.3 A high level of personal diligence and appropriate procedures are required to ensure an acceptable level of safety is maintained.

14.2 Proximity to Aircraft

- 14.2.1 Drivers must always give way to moving aircraft even when the aircraft is under tow.
- 14.2.2 Drivers must not drive a vehicle within **5 meters** of a parked aircraft, except when required for the servicing of that aircraft. A vehicle may only be used to service, load or unload an aircraft if a representative of the aircraft operator or handling agent is present to direct the movements of that vehicle.
- 14.2.3 Personnel and Drivers must not drive/walk behind, and must stay well clear of, aircraft when their red/white anti-collision beacons and/or strobes are operating as this indicates that:
- (a) The engines are running or are about to be started.
 - (b) The aircraft is about to move or be pushed back.
 - (c) On arrival on the stand, indicate that an aircraft brake is overheated, or the aircraft is still live and should not be approached.
- 14.2.4 Personnel and drivers must not drive/walk along any section of the apron road that crosses the aircraft entry or exit point to a stand, whilst an aircraft on that stand has its red/white anti-collision beacons.
- 14.2.5 For stationary aircraft with its engine(s) running, personnel must:
- (a) Remain at least **7.5 meters** from the front and side of an aircraft engine; and
 - (b) Not pass within **31 meters** from the rear of a jet aircraft.
- 14.2.6 For moving jet aircraft with engine(s) running, personnel must:
- (a) Not pass within **150 meters** from the rear of the aircraft jet engine.
- 14.2.7 Drivers must ensure that safe distances are maintained from operating aircraft and that wingtip clearances to vehicles are maintained.

[PRINTED COPIES ARE UNCONTROLLED]

14.2.8 For aircraft manoeuvring in the vicinity of an aircraft stand, the aircraft-to-object separation is:

CODE	Separation (metres)
A	3.0
B	3.0
C	4.5

14.2.9 Typical aircraft operating at Queenstown Airport are:

CODE	Maximum Wingspan (metres)
A	15m (Cessna 206, Britten Norman Islander)
B	24m (Cessna Caravan, Beechcraft 200)
C	36m (ATR72, Boeing 737, Airbus A320)

14.2.10 Drivers must not operate a vehicle in reverse in the vicinity of aircraft unless he/she has established it is safe to do so.

14.2.11 Drivers must adhere to the “Circle of Safety” rule at Queenstown Airport. This rule requires that all vehicle/equipment operators:

- (a) Test the brakes at **5 meters** from the aircraft and
- (b) Come to a complete stop at no less than **2 meters** from the aircraft, and then proceed at a slow walking pace.

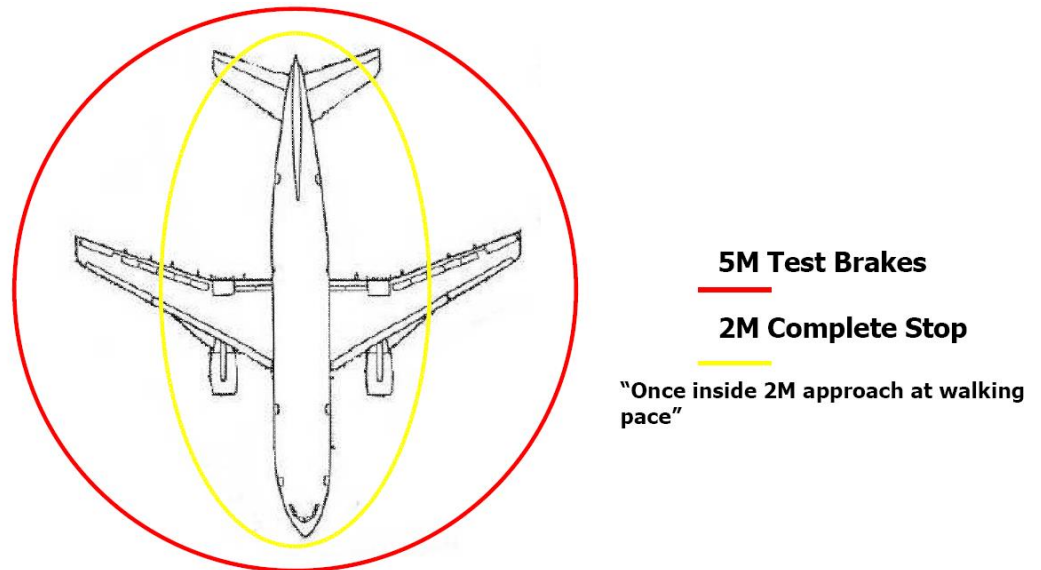

Figure 14-1 - Circle of Safety

14.3 Operating Underneath Aircraft

14.3.1 It is prohibited to drive between aircraft engines underneath any fuselage or wings of an aircraft unless operationally approved for that specific aircraft type.

14.4 Jet Aircraft Danger Zones

- 14.4.1 Jet engines operate by the consumption of large amounts of air into the intake at the front of the engine. This air is then compressed to a high pressure, injected with fuel, and ignited. The high energy of combustion is used to drive the turbines, which power the engine. The air and exhaust gasses are expanded in the turbines and then expelled through the rear of the engine at very high speeds and very high temperatures, thus propelling the aircraft.
- 14.4.2 Both engine ingestion and jet blast can be fatal to people and can cause a great deal of damage to other aircraft, vehicles, and equipment. A jet engine is very powerful, even when taxiing, starting up or shutting down.
- 14.4.3 Personnel are not permitted to enter the aircraft danger areas while an engine is operating or the beacon/strobe lights are illuminated. This is for their safety and well-being.
- 14.4.4 Refer to Figure 14-2 – Airbus A320 Aircraft Danger Areas, which depicts the danger areas for the Airbus A320.
- 14.4.5 **Never** approach a jet aircraft whilst its engines are operating.

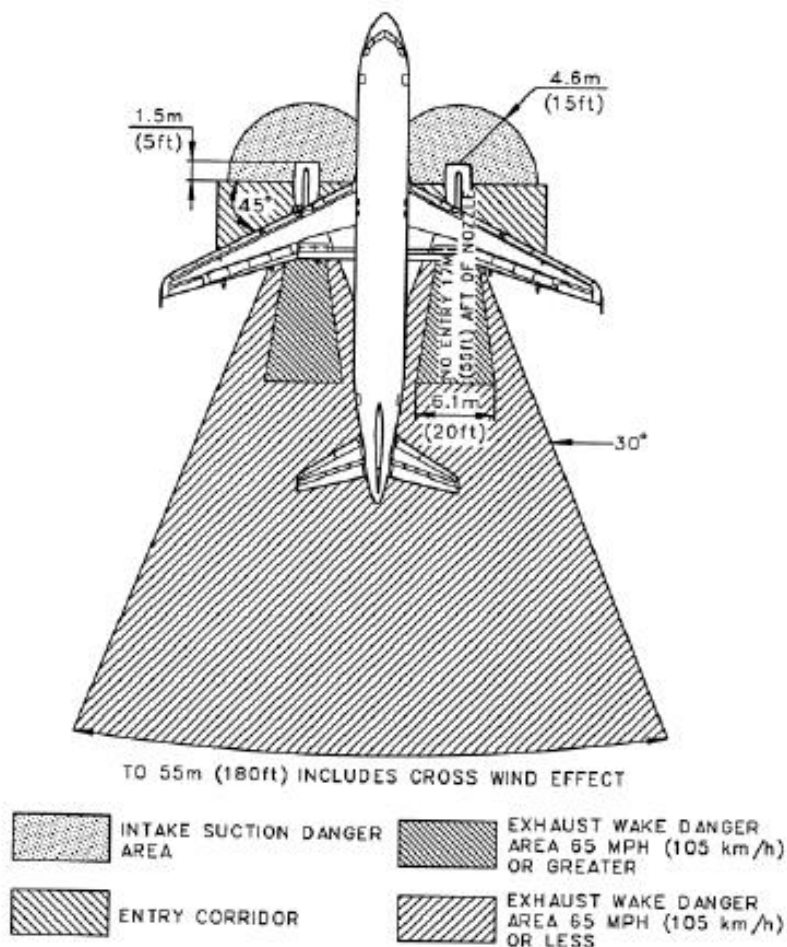

Figure 14-2 – Airbus A320 Aircraft Danger Areas (Idle Thrust)

14.5 Propeller Aircraft Danger Zones

- 14.5.1 Propeller-driven aircraft operate differently from jet engines because they use one or more spinning propellers to drive the aircraft forward. A propeller spins at a high velocity around a propeller shaft and generates lift, which acts in the forward direction thus propelling the aircraft. In doing so, the air ahead of the propeller is sucked in and expelled through the propeller at a higher velocity, which also aids the propulsion.
- 14.5.2 Propellers are particularly dangerous because they spin at a high velocity that it is difficult to see. It may also be difficult to hear a propeller engine operating due to the high ambient noise levels at an aerodrome. Accidentally walking into an operating propeller has seriously injured many people.
- 14.5.3 Always walk around the wing of a propeller-driven aircraft. See Figure 14-3 - ATR 72 which depicts the danger zones typical of a propeller-driven aircraft.

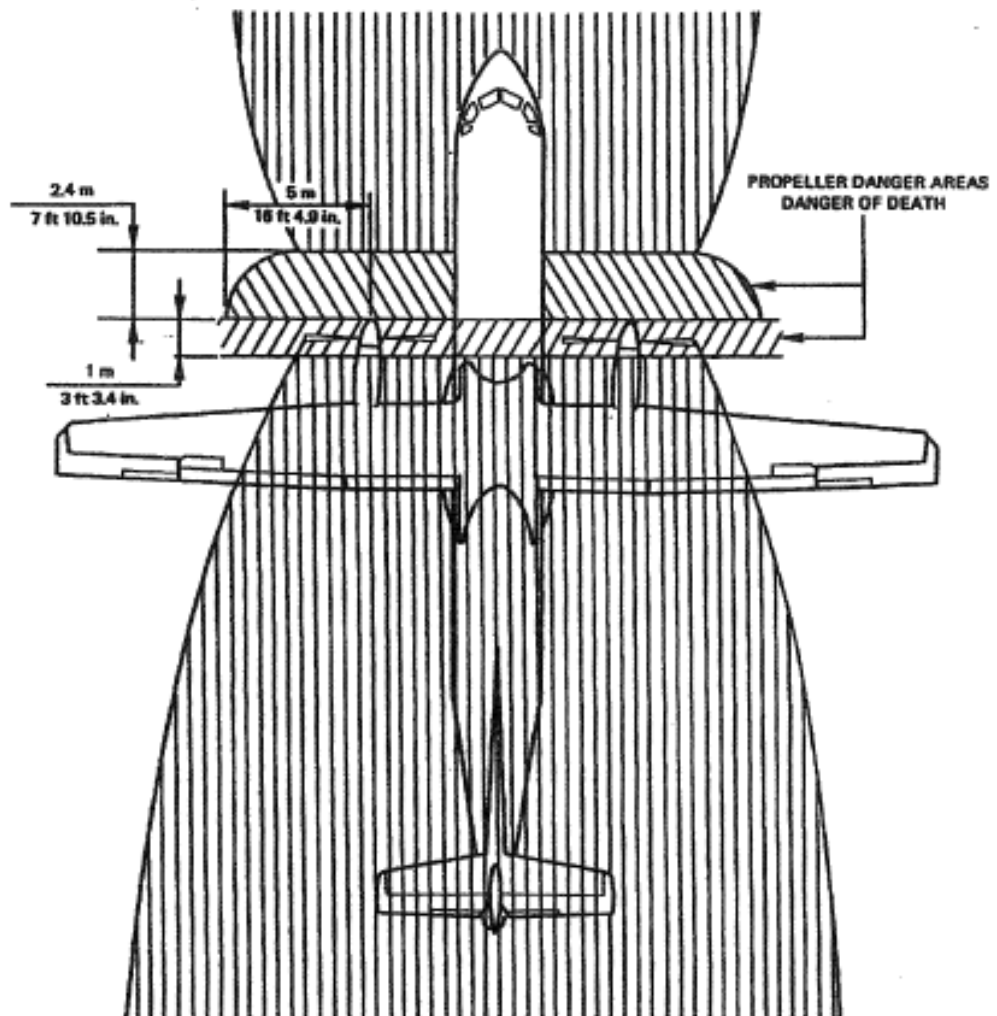

Figure 14-3 - ATR 72 Aircraft Danger Areas (Idle Thrust)

14.6 Helicopters

14.6.1 Helicopter Operations can be particularly dangerous as the propeller or rotor, even at idle power, has sufficient force to cause fatal or serious injuries. The following procedures should apply to all helicopter operations.

- (a) Never approach the rear of a helicopter because of the danger imposed by the engine exhaust and tail rotor.
- (b) Approach a helicopter from the front or side and ensure you are in the pilot's line of vision.
- (c) If possible, approach the helicopter up the slope and depart on the downward slope to avoid the main rotor blade.
- (d) Crouch low before going under the main rotor.
- (e) Hold onto any loose articles, such as hats, and do not give chase if they are blown away.
- (f) Eyes should be protected from any dust or blowing objects.
- (g) If eyes become blinded by foreign debris crouch or sit down and wait for assistance. Do not continue to approach the helicopter.
- (h) Never drive or park any vehicle or large equipment under the main or tail rotor blades.

14.6.2 No person is permitted within **30 meters** of a helicopter unless essential to the helicopter operation.

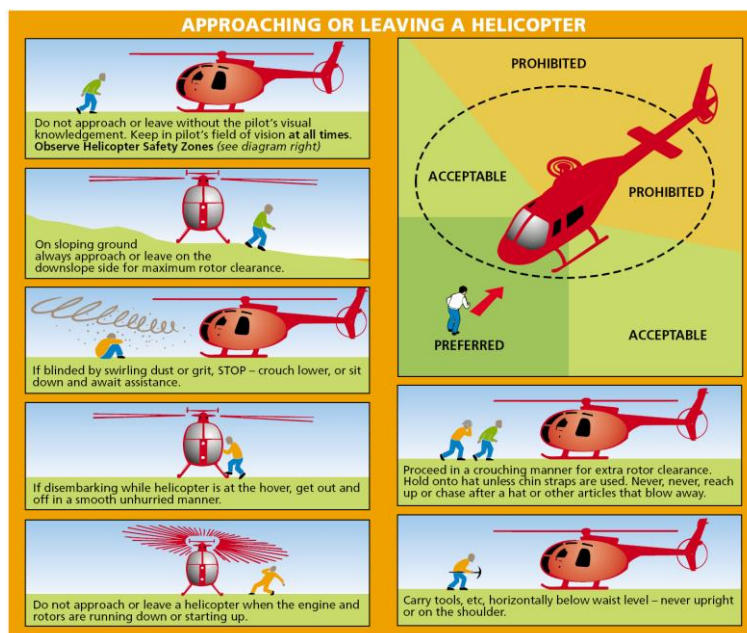

Figure 14-4 - Helicopter Danger Areas

15 ACCIDENTS, INCIDENTS & EMERGENCIES

15.1 Introduction

- 15.1.1 In the interest of safety, QAC's primary concern is to encourage the full and uninhibited reporting of any incident, accident, hazard, or safety concern that might affect the safety of persons, property, or aircraft.
- 15.1.2 It is the responsibility of all personnel to report any circumstance affecting safety.
- 15.1.3 It is not the policy of QAC to institute disciplinary procedures in response to reporting any occurrence; however in cases where it becomes apparent that a dereliction of duty amounting to gross negligence has occurred, disciplinary action may follow. Refer to Part 18 for details on the penalties system.

15.2 Reporting Incidents

- 15.2.1 If a person is involved in, or a witness to an incident, they must report it within 24 hours via QAC's online reporting tool bit.ly/QACIncidentForm.
- 15.2.2 If the incident results in injury to people, damage to QAC property, or if any residual risk remains, QAC must be notified immediately by calling **(03) 450 9221** in addition to 15.2.1.
- 15.2.3 Any person(s) involved in or witness to an incident is required to disclose full details of the incident to QAC via the online reporting tool: bit.ly/QACIncidentForm. Failure to provide information or giving false/misleading information is an offence.

Note: If an incident involves injury or illness, the priority is to avoid further harm, provide first aid assistance and/or get assistance from qualified staff or emergency services if required. QAC Airport Emergency Services can be contacted on **(03) 450 9058**

15.3 Vehicle Breakdowns

- 15.3.1 If a vehicle becomes immobilised on the Manoeuvring area, the driver must immediately report this fact to Queenstown Tower. If unable to contact ATC, remain with the vehicle and notify QAC Airport Emergency Services on **(03) 450 9058**.
- 15.3.2 If a vehicle becomes immobilised on an Apron area, the driver must notify the QAC Airport Emergency Services on **(03) 450 9058**.
- 15.3.3 The driver of any vehicle which becomes immobilised on an Apron area must provide QAC staff such assistance as requested to move the vehicle off the Apron.

15.4 Waste and Spills

- 15.4.1 A person must not:
- (a) Leave any waste or litter (including confetti) at the airport other than in the waste containers provided; or

[PRINTED COPIES ARE UNCONTROLLED]

- (b) Leave or spill on any surface at the airport any oil, grease, fuel, or anything else likely to cause damage or create a hazard or obstruction.

15.4.2 A person who breaches subclause 15.4.1(b) must:

- (a) Immediately tell QAC IOC; and
- (b) At the persons own cost, remove the thing that was left or spilled in the area and return the area to the state it was in before the breach.

15.4.3 Any person with a lease, licence, or concession to use an area of the airport must keep the surface of the area clear of oil, grease, fuel, and anything else likely to cause damage or create a danger or obstruction.

15.4.4 To fulfil the obligation of subclause 15.4.2(b) an airport user may contact QAC AES **(03) 450 9058**, who holds spill cleaning kits or can contact a contractor to deal with any significant sewage spillage.

15.4.5 In instances where QAC arranges the clean-up, it should be expected that QAC will charge the company responsible for the spillage for the costs associated with returning the area to its previous state.

15.5 Compliance, Hazards and Safety Concerns

15.5.1 A safety concern reporting system is in place as part of QAC's safety and quality management system. This system allows persons to advise QAC of compliance, hazards, or safety concerns that could potentially affect the safety of people, property, or aircraft.

15.5.2 A "Hazard" is defined as any potential or actual source of harm. Hazards are, however, not just limited to workplace health and safety; they also exist in aviation and aircraft safety.

15.5.3 Anyone may complete a report through the QAC [OneReg](#) system to report any hazard or safety concern that could cause an accident or incident. The form can be submitted anonymously (if required) by omitting the relevant details.

15.5.4 All reports received will be recorded, evaluated, and investigated following the QAC Safety Management System Framework procedures. Reported safety concerns will be acknowledged and analysed, and corrective or preventative action taken.

16 AERODROME MARKINGS & SIGNAGE

16.1 Runway Strip and Work Zones

- 16.1.1 Runway strips are marked by white marker boards. These boards mark the boundary of the runway strip and are parallel on both sides of the runways.



16-1 - Runway Strip Edge Marking

- 16.1.2 Work zones around Runway 05-23 have been established that enable specific scenarios where work can be undertaken while runways are in use. Any work conducted outside these zones has no special restrictions, apart from Obstacle Limitation Surface (OLS) requirements.
- (a) Zone 1: This rectangular zone extends symmetrically around the runway. Its sides are 45m from the runway centreline, and it extends 60m from the runway ends.
 - (b) Zone 2: This rectangular zone extends symmetrically around the runway. Its sides are 75m from the runway centreline.
- 16.1.3 Clearance must be obtained from ATC for entry into these zones. Refer to Part 19 for the Work Zones chart. Refer to section 13.13 for information on operating in the manoeuvring area.

16.2 Taxiway Centre Line Markings

- 16.2.1 Aircraft place the nose wheel on the taxiway guideline to ensure that the aircraft is safely within the limits of the taxiway. Vehicles on a taxiway should always travel along the taxiway guidelines to ensure that other vehicles can observe the vehicle's movements.

[PRINTED COPIES ARE UNCONTROLLED]



16-2 - Taxiway Centre Line marking

16.3 Taxiway Edge Line Markings

16.3.1 The taxiway edge line defines the edge of the load-bearing taxiway surface.



16-3 - Taxiway Edge Marking

16.4 Runway Hold Point Markings

- 16.4.1 Holding points are located on all taxiways that lead to a runway. A clearance from ATC must be obtained before proceeding past any hold point, with the solid section of the line closest to the vehicle. Taxiway hold point markings are co-located with Runway designation signs. See clause 16.14.1 below.



16-4 - Runway Hold Point Marking – Alpha 3

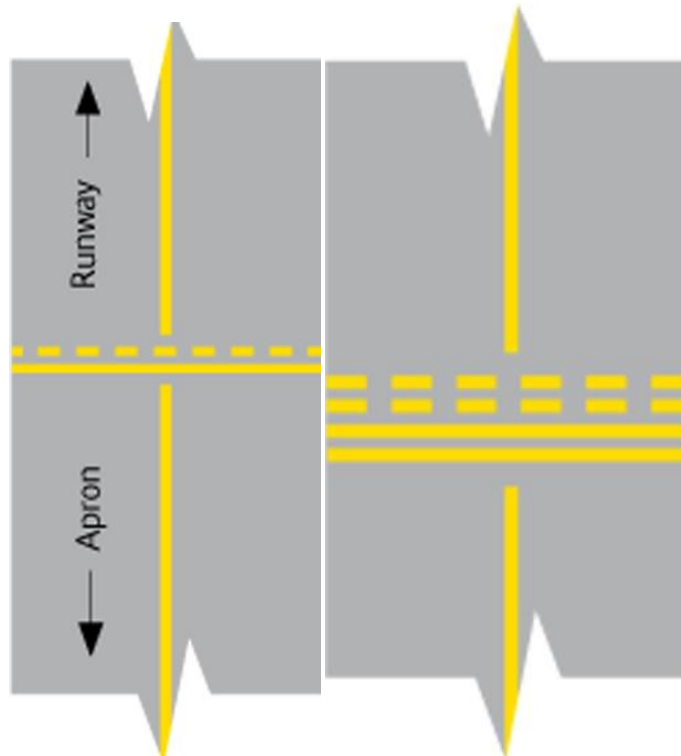

16-5 - Runway Hold Point Markings

16.5 Intermediate Holding Position

- 16.5.1 Where two taxiways cross/intersect, yellow broken lines mark the clearance distance for vehicles to remain behind when aircraft cross ahead.

16.6 Equipment Storage Areas & Apron Safety Line

- 16.6.1 Vehicles and equipment must be stored in designated storage areas when not being used to service aircraft.

[PRINTED COPIES ARE UNCONTROLLED]

- 16.6.2 No personnel, except those approved to conduct certain aircraft handling functions, are permitted beyond the equipment storage line when aircraft anti-collision beacons are on.



16-6 - Equipment Storage Limit Line

16.7 Fire Hydrant Markings

- 16.7.1 Fire hydrants in airside areas are marked by a yellow circle and must always be kept clear of vehicles and equipment.



16-7 - Fire Hydrant marking

16.8 Pushback Tug Guidance Lines

- 16.8.1 Pushback tug guidance lines are provided on the apron to assist tug operators safely manoeuvring aircraft from the aircraft stands. They serve as guidance only and do not eliminate the tug driver's responsibility to manoeuvre the aircraft clear of other aircraft and obstacles safely.

[PRINTED COPIES ARE UNCONTROLLED]



16-8 - Pushback tug guidance lines

16.8.2

The following photo depicts a pushback limit point. They enable aircraft to be pushed back and held clear of other parked or taxiing aircraft, ensuring clearance from pavement edges and other obstacles.



16-9 - Pushback limit marking

16.9

Passenger Walkway Lines

16.9.1

Passenger guidance markings are provided on the apron to assist the orderly movement of passengers embarking and disembarking aircraft. Passenger guidance markings are blue, and pedestrian crossings are white per New Zealand roading standards.



16-10 - Passenger Walkway line

16.10 Apron Service Road

16.10.1 The apron service road is marked the same as a normal road in white paint. Vehicles traversing the apron should use this road. Stop lines are located at various points on the service road and indicate the mandatory stop position when an aircraft is manoeuvring onto the aircraft stand ahead of the Stop Line.

Drivers must, however, maintain adequate clearance from aircraft taxiing on the apron, as the apron road does not provide adequate separation. Refer to clause 14.2 regarding clearances from operating aircraft.



16-11 - Apron Service Road

16.11 Apron Road and Apron Taxiway Separation

16.11.1 The boundary between the Apron Service Road and the Apron Aircraft Taxiway is marked by a double white line.

16.11.2 Sections of the Apron Service Road that are infringed by aircraft wingtips are marked by alternating dashed white lines. Drivers must give way to aircraft taxiing through these sections.

[PRINTED COPIES ARE UNCONTROLLED]

- 16.11.3 Drivers should note that this double white line also demarks the boundary of the Airways apron control. Drivers must not cross this marking unless they meet the requirements of part 9.18 (Operating on the Manoeuvring area) of this manual.



16-12 – Demarcation between the apron service road and apron taxiway

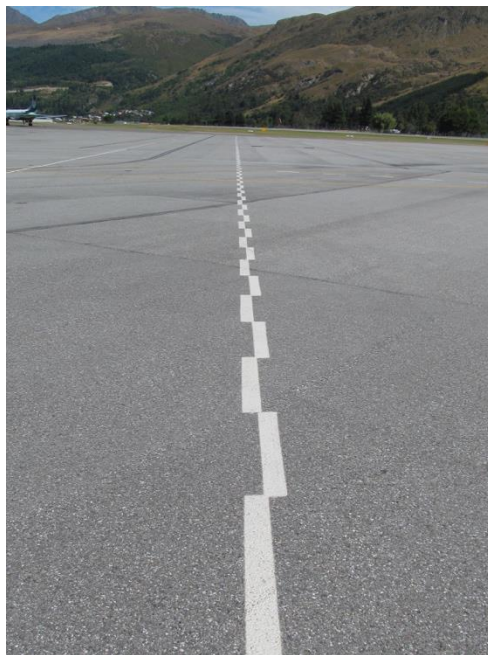

16-13 – Section of apron road infringed by aircraft wingtip

16.12 Roadway Signage

- 16.12.1 Common traffic signs such as Stop, No Entry and Maximum Speed signs and information signs shown below are also displayed airside and must be obeyed. STOP signs or STOP lines mean the vehicle must come to a complete stop.

[PRINTED COPIES ARE UNCONTROLLED]



16-14 - Stop Sign (Taxiway Crossing)



16-15 - No Entry Sign



16-16 – Stop lines

16.12.2 Live taxiway crossings are marked with Stop signs. Vehicles must stop at the designated Stop Sign and give way to moving aircraft if they are approaching, then cross carefully, allowing for jet blast or prop wash.

16.13 Aircraft Stand Clearways

16.13.1 Aircraft Stand clearways exist between some aircraft stands on the main terminal apron to allow safe movement between stands. No GSE is to be left unattended in a clearway.

[PRINTED COPIES ARE UNCONTROLLED]



16-17 – Interstand Clearway

16.14 Movement Area Guidance Signs (MAGS)

16.14.1 All Drivers must stop at the Runway designation signs co-located with runway hold point markings and seek clearance from ATC to enter or cross the Runway.



16-18 - Runway Designation Sign

16.14.2 The above runway designation sign depicts the sign provided at a Runway/Taxiway intersection. This sign indicates the direction of Runway 32-14 (white numerals on red background) and that you are on Taxiway B4 (Taxiway location sign: yellow numerals on black background). Yellow on Black is where you're at, Black on Yellow is where you are going.

[PRINTED COPIES ARE UNCONTROLLED]



16-19 - Taxiway Location Sign

16.14.3

The photo below depicts a NO ENTRY sign consisting of a white circle with a horizontal bar in the middle on a red background. This indicates that the aircraft are not permitted on the roadway.



16-20 - Aircraft No Entry Sign

16.14.4

The photo below depicts signage to advise pilots of the taxiways about to be joined or crossed. An arrow indicates each taxiway's direction. The signs below indicate that Taxiway A4 and Taxiway A3 are approaching and are located on the left.



16-21 - Taxiway Direction Signs

17 RADIO PROCEDURES

17.1 Introduction

17.1.1 Personnel applying for, or in possession of a Category 3 ADP are required to hold an aeronautical radio certificate of proficiency or equivalent. For compliance with the Radio Communications Regulations 2001, the successful completion and award of a Category 3 ADP meets this requirement under equivalency.

17.2 Good Radio Practice and Transmitting Technique

17.2.1 Before you transmit, you should ensure that the volume and squelch controls are set correctly on your radio. If you plan to work outside the vehicle and it is equipped with a fixed unit, ensure that you have a handheld unit available.

17.2.2 Be familiar with microphone operating techniques and do not turn your head away from the microphone while talking or vary the distance between it and your mouth.

17.2.3 Severe distortion may arise from talking too close to the microphone or touching the microphone with your lips.

17.2.4 The Tower frequency (118.1 MHz) at Queenstown gets busy at times, so it is important to listen before transmitting. Do not interrupt anyone else and allow time for any necessary reply from someone else.

17.2.5 Use a normal conversation tone and speak clearly and distinctly. A slight pause before and after numbers will help them be easier to understand.

17.2.6 Depress the transmit switch fully before speaking and do not release it until the message is complete. This will ensure the entire message is transmitted. However, do not depress the transmit switch until you are ready to speak.

17.2.7 **Think about what you will say before you transmit.** It may help to write down what you will say beforehand.

17.2.8 Avoid hesitation sounds such as “er” and maintain a constant speaking volume.

17.2.9 It is important to speak slowly and clearly and use standard words and phrases as much as possible.

17.2.10 One of the most dangerous situations in radiotelephony is a ‘stuck’ microphone button. You must ensure that the button is released after a transmission and that the microphone is placed appropriately to prevent it from being inadvertently activated.

17.3 Phonetic Alphabet

17.3.1 The International Phonetic Alphabet assists in voice transmission of call signs, taxiway designators, runways and the spelling of proper names and unusual words. Syllables to be emphasised are in upper case.

[PRINTED COPIES ARE UNCONTROLLED]

LETTER	SPOKEN AS	PRONUNCIATION	LETTER	SPOKEN AS	PRONUNCIATION
A	ALPHA	AL fah	N	NOVEMBER	no VEM ber
B	BRAVO	BRAH voh	O	OSCAR	OSS cah
C	CHARLIE	CHAR lee	P	PAPA	pah PAH
D	DELTA	DELL tah	Q	QUEBEC	keh BECK
E	ECHO	ECK ho	R	ROMEO	ROW meoh
F	FOXTROT	FOKS trot	S	SIERRA	see AIR rah
G	GOLF	GOLF	T	TANGO	TANG go
H	HOTEL	ho TELL	U	UNIFORM	YOU nee form
I	INDIA	IN dee ah	V	VICTOR	VIK tah
J	JULIET	JEW lee ETT	W	WHISKEY	WISS key
K	KILO	KEY loh	X	XRAY	ECKS ray
L	LIMA	LEE mah	Y	YANKEE	YANG key
M	MIKE	MIKE	Z	ZULU	ZOO loo

17.4 Pronunciation of Numbers

17.4.1

The following table lists the phonetic spelling of numbers and number terms. Syllables to be emphasised are in upper case.

NUMBER	PRONUNCIATION	NUMBER	PRONUNCIATION
0	ZE-RO	7	SEVen
1	WUN	8	AIT

[PRINTED COPIES ARE UNCONTROLLED]

2	TOO	9	NINer
3	TREE	Decimal	DAY SEE MAL
4	FOWer	Hundred	HUN dred
5	FIFE	Thousand	TOU SAND
6	SIX		

17.4.2

All numbers used to transmit callsigns, runways designators, times and frequencies must be pronounced by pronouncing each digit separately.

Application	Example	Transmitted As	Pronounced as
Callsigns	NZ636	New Zealand six three six	New Zealand SIX TREE SIX
	SECURITY1	Security one	Security WUN
	RESCUE4	rescue four	Rescue FOW-ER
Runway Designator	23	Runway two three	Runway TOO TREE
	05	Runway zero five	Runway ZERO FIFE
Time	0936	Zero nine three six	ZE-RO NIN-er TREE SIX
Frequencies	118.1	one one eight decimal one	WUN WUN AIT DAY SEE MAL WUN

17.4.3

When transmitting time, each digit must be pronounced separately. Only the minutes of the hour are normally required.

TIME	TRANSMITTED AS	PRONOUNCED AS
0903	ZERO THREE or ZERO NINE ZERO THREE	ZE-RO TREE or ZE-RO NINer ZERO TREE
1200	ONE TWO ZERO ZERO	WUN TOO ZE-RO ZE-RO
1734	THREE FOUR or ONE SEVEN THREE FOUR	TREE FOWer or WUN SEVen TREE FOWer

17.5 Radio Testing

17.5.1 A radio check is required for routine radio checks or whenever it is suspected that radio equipment may not be performing correctly.

17.5.2 The test transmission must take the following form:



- (a) The identification of the station being called.
- (b) The vehicle callsign.
- (c) The words RADIO CHECK.

17.5.3 Replies to the test transmission will be as follows:

- (a) The identification of the station calling.
- (b) The identification of the station replying.
- (c) Information regarding the readability of the transmission.

17.5.4 The readability of the transmission must be classified by one of the following readability scales:

1. Unreadable.
2. Readable now and then.
3. Readable but with difficulty.
4. Readable.
5. Perfectly readable.

RTF	Conducting a Radio Check
	QUEENSTOWN TOWER, RESCUE 4, RADIO CHECK
	RESCUE 4 TOWER, READABILITY THREE, LOUD BACKGROUND WHISTLE

17.5.5 The minimum acceptable standard for readability on Queenstown Aerodrome is 'Four'.

17.6 Standard Words and Phrases

17.6.1 Using standard words and phrases helps prevent misunderstandings which can contribute to accidents. It also reduces the need for additional transmissions. The following words and phrases used in RTF communications have the specific meaning given below.



WORD/PHRASE	MEANING
ACKNOWLEDGE	Let me know that you have received and understood this message
AFFIRM	Yes
APPROVED	Permission for proposed action granted
BREAK	Indicates separation between messages
BREAK BREAK	Indicated separation between messages to different callsigns in a busy environment
CANCEL	Cancel the previously transmitted clearance
CHECK	Examine a system or procedure
CONFIRM	I request verification of: (clearance, instruction, action, information)
CONTACT	Establish communications with
CORRECT	True or accurate
CORRECTION	An error has been made in this transmission (or message indicated). The correct version is.....
DISREGARD	Ignore
EXPEDITE	Carry out an action at best rate/speed
GO AHEAD	Proceed with your message (Not to be used whenever the possibility exists of misconstruing GO AHEAD as an authorisation to proceed)
HOLD POSITION	Do not proceed until you have received permission
HOLD SHORT	Stop before reaching the specified location

[PRINTED COPIES ARE UNCONTROLLED]

HOW DO YOU READ	What is the readability of my transmission?
I SAY AGAIN	I repeat for clarify or emphasis
MONITOR	Listen out on (frequency)
NEGATIVE	No or Permission, not granted, that it is not correct or not capable
READ BACK	Repeat all, or the specified part, of this message back to me exactly as received
REPORT	Pass the requested information
REQUEST	I should like to know, or I wish to obtain
ROGER	I have received all or your last transmission (<i>under NO circumstance to be used in reply to a question requiring READBACK or a direct answer in the affirmative or negative</i>)
SAY AGAIN	Repeat all, or the following part of your last transmission
SPEAK SLOWER	Reduce your rate of speech
STANDBY	Wait and I will call you
UNABLE	I cannot comply with your request, instruction or clearance (<i>normally followed by reason</i>).
WILCO	I understand your message and will comply with it (<i>abbreviation for will comply</i>)

17.7 Establishment and Continuation of Communications





17.7.1 When first establishing communication, drivers should use the full callsigns of both stations, saying first whom they are calling (e.g. Queenstown Tower), and then who they are (e.g. Security 1).

RTF	Establishing Communication
	Queenstown Tower, Rescue 4
	Rescue 4, Queenstown Tower, go ahead

[PRINTED COPIES ARE UNCONTROLLED]

17.7.2 Once satisfactory communication has been established, only the vehicle callsign is normally used. However, the placing of the vehicle callsign within the message is also important. When an exchange is initiated, the message is prefixed with the vehicle callsign, regardless of whether the vehicle driver or the ATC controller initiated the exchange. This includes messages where the driver wishes to transmit new information or a request.

17.7.3 However, when the driver needs to read back an instruction or important information, the instruction or information is repeated first, followed by the vehicle callsign.

RTF	Continuing Communication
	Rescue 4, report your position
	Rescue 4, on taxiway Alpha, request clearance around the boundary <i>(Note: vehicle driver <u>indicates</u> exchange, so <u>starts</u> with vehicle callsign)</i>
	Rescue 4, cleared around the boundary
	Cleared around the boundary, Rescue 4 <i>(Note: driver <u>reads back</u> instructions, so <u>ends</u> with vehicle callsign)</i>

17.8 Broadcast Information

17.8.1 When an ATC controller wishes to broadcast information to all aircraft and/or vehicles likely to receive it, the message will be prefaced by the phrase 'all stations'.



17.8.2 No reply to such general calls is necessary unless individual aircraft or vehicles are subsequently called upon to acknowledge receipt, or the recipient needs to query the information.

RTF	Broadcast Information
	All stations, Queenstown Tower, distress traffic on final runway 32

17.9

17.10 Acknowledging Instructions

- 17.10.1 Vehicle drivers are required to read back in full all instructions relating to movement in the manoeuvring area. The manoeuvring area is part of the aerodrome provided for aircraft take-off and landing and for aircraft movement on the surface, excluding the apron and any part of the aerodrome provided for aircraft maintenance.
- 17.10.2 Examples of messages that require a readback include:
- (a) Clearances to enter or cross a runway.
 - (b) Instructions to remain on or hold clear of a runway.
 - (c) Movement instructions, including route and holding points where specified.
- 17.10.3 Because misunderstandings regarding these instructions could have serious safety consequences, drivers must read back in full the message they have received to confirm there is no misunderstanding.
- 17.10.4 Drivers should note that the expression 'wilco', meaning 'I understand your message and will comply', is no substitute for a full readback of a movement instruction.
- 17.10.5 If a readback of a movement instruction is not received, the driver will be told to do so. Additionally, if the driver does not fully understand the instructions, they must request that they be repeated or clarified.
- 17.10.6 Some transmissions require a defined response from the driver and should be answered appropriately with the information requested, not with 'roger'. Other transmissions contain information, and drivers should acknowledge by transmitting their callsign or the word 'roger' followed by their callsign. This means 'I have received all your last transmission'.

RTF	Acknowledgements
	Queenstown Tower, Rescue 4, at Bravo 4, clearance across Runway 14
	Rescue 4, proceed across Runway 14 <i>(Note: this is a movement instruction and must be read back)</i>
	Proceed across Runway 14, Rescue 4
	Rescue 4, caution company vehicle on Runway 14 <i>(Note: this is information)</i>



[PRINTED COPIES ARE UNCONTROLLED]

	Roger, Rescue 4
---	------------------------

17.11 Proceeding to a defined position & 'Hold Position'

17.11.1 If ATC is busy, the driver will be instructed too 'standby'. This means that the driver should wait until the controller calls back. The driver must not proceed until permission is given.



17.11.2 When there is conflicting traffic, the ATC controller may reply 'hold position'. This means the driver must not proceed until the controller requests permission.

RTF	Instruction to Hold Position
	Queenstown Tower, Rescue 4, request clearance across runway 23 to Bravo 1
	Rescue 4, hold position, Boeing 737 landing runway 23
	Holding, Rescue 4

17.12 Entering, Crossing and Vacating Runways

17.12.1 Vehicles will often need to enter a runway to carry out tasks such as i.e. surface or lighting inspections.

17.12.2 Be careful whenever seeking approval to enter a runway, ensuring that you are on the correct frequency and know what you wish to say.

RTF	Entering a Runway
	Queenstown Tower, Rescue 4, Alpha 3, clearance on to runway 23 for inspection
	Rescue 4, proceed onto runway 23

[PRINTED COPIES ARE UNCONTROLLED]

	<p>Proceed onto runway 23, Rescue 4</p>
---	--

17.12.3 When a driver is instructed to vacate the runway, the driver must read back the instructions. A runway vacated report should not be made until the vehicle or associated vehicles being escorted, are clear of the designated runway area. This will be once the appropriate runway holding point has been passed.



17.12.4 To avoid misunderstanding, the driver must use the expression 'vacated' and **not** 'clear; or 'cleared'.

RTF	Vacating the Runway
	<p>Rescue 4, vacate Runway 23 at Alpha 5</p>
	<p>Vacate at Alpha 5, Rescue 4</p>
	<p>Rescue 4, clear and remaining clear at Alpha 5</p>
	<p>Rescue 4</p>

17.12.5 When the planned route involves a runway crossing, the driver should include this information in their request. Under no circumstances should a driver cross or enter a runway unless a specific instruction has been issued and acknowledged.





17.12.6 Sometimes, it may not be possible for ATC to give permission to cross or enter a runway. The driver may be instructed to take a different route from that requested.

RTF	Refusal of Permission to Cross a Runway
	<p>Queenstown Tower, Rescue 4, request clearance across grass 32 to taxiway alpha</p>

	<p>Rescue 4, negative, proceed to taxiway alpha via the boundaries</p>
	<p>Proceed to taxiway alpha via the boundaries, Rescue 4</p>

17.13 Radio Emergency Procedures

- 17.13.1 If the driver suspects, for any reason the radio has ceased to operate, he/she should vacate the manoeuvring area without entering or crossing a runway.
- 17.13.2 The ATC controller may communicate with vehicles using the following light signals. Drivers should keep a look out for them, and understand these signals, which are as follows.

Signal	Meaning
	<p>STOP IMMEDIATELY</p>
	<p>MOVE OFF LANDING AREA OR TAXIWAY, WATCH FOR AIRCRAFT</p>
	<p>PERMISSION TO MOVE ON TO LANDING AREA OR TAXIWAY</p>
	<p>INCREASE SPEED IN SAME DIRECTION</p>
	<p>REPORT TO TOWER, MOVE VIA THE BOUNDARY</p>



17.14 Unattended Aerodrome Procedures

- 17.14.1 Outside ATC hours of service, as published in the AIPNZ supplement, drivers must adhere to these unattended aerodrome procedures.
- 17.14.2 Operating in the manoeuvring area outside these hours requires aircraft and vehicles to broadcast their intentions on the unattended aerodrome frequency (118.1 MHz).
- 17.14.3 Before moving onto the manoeuvring area, drivers must:

[PRINTED COPIES ARE UNCONTROLLED]

- (a) Maintain a listening watch on the unattended aerodrome frequency (118.1 MHz);
- (b) Make a call on 118.1 MHz to "Queenstown Traffic" advising intentions;
- (c) Ensure that the runway or taxiway is clear of aircraft and that no aircraft are taking off or landing.

17.14.4 Keep radio calls concise and use the standard phraseology. Avoid verbose accounts of your intentions.

RTF	Intention Broadcasts
	Queenstown Traffic, Rescue 4, moving on to runway 23 for inspection
	Queenstown Traffic, Rescue 4, clear of runway 23
	Queenstown Traffic, Rescue 4, proceeding around the boundaries

17.14.5 If an aircraft broadcasts its intentions, drivers must respond with a radio call broadcasting their intentions and moving clear of any runway or taxiway intended for use by the aircraft.

RTF	Communicating with Aircraft
	Queenstown Traffic, Delta Bravo Uniform, on finals runway 14
	Delta Bravo Uniform, Rescue 4, vacating runway 14
	Rescue 4, Delta Bravo Uniform, roger thanks
	Queenstown Traffic, Rescue 4, clear of all runways

[PRINTED COPIES ARE UNCONTROLLED]

17.15 De-icing Truck procedures

17.15.1 For standard de-icing procedures at runway holding position A3 during ATC hours of service, contact Queenstown Tower (03) 450 9182.

18 PENALTIES

18.1 Introduction

- 18.1.1 At the discretion of QAC, persons found to be acting or driving contrary to any of the rules, regulations and procedures contained in these Queenstown Aerodrome Safety and Compliance Regulations or any other reasonable request by QAC may accumulate demerit points against their personnel record.
- 18.1.2 In certain circumstances, QAC may review the points allocated and, depending on the circumstances surrounding the offence, including the severity and possible consequence (e.g., death, disability, injury, property damage etc.), may increase the points issued.
- 18.1.3 Points issued are valid for 36 months from the date of issue, and if a person commits multiple offences in a single event, points will be issued cumulatively for each of the given actions.
- 18.1.4 If an Airport Infringement Notice (AIN) is issued to any person, it will be recorded on their personal record by QAC, and notification will also be forward to the person's employer. Any details recorded on a personal record including demerit points are unaffected by any administrative changes, including but not limited to the issue of new ADP's, changes with employment or the employer.
- 18.1.5 The following table details the offences that may result in an AIN and the appropriate demerit points. Note that these are subject to change from time to time and are only deemed correct as at the time of printing.
- 18.1.6 Accumulating 12 or more Demerit Points in any one of the below categories within a 36-month period, may result in suspension or withdrawal of a relevant competency or area.
- 18.1.7 Accumulating 16 Demerit Points combined through any category within a 36-month period, may result in restriction or withdrawal of Airport Access and/or an individual retraining plan to be completed.

18.2 Entity Access

- 18.2.1 Should QAC consider that a material number of Demerit Points have been accumulated by individuals engaged by the same entity (which may be the employer or contractor of the individuals), it may deem this to be an indication that the entity is failing to take its safety or security obligations seriously, and putting QAC at risk of breaching its own obligations including but not

[PRINTED COPIES ARE UNCONTROLLED]

limited to Civil Aviation Rules, Health and Safety or Ministry for Primary Industries. In such situations, QAC reserves the right to restrict access fully or partially to all individuals engaged by that entity by suspending, withdrawing, or amending such permits, access cards and approvals as it sees fit per this section.

- 18.2.2 QAC may suspend all permits, access cards, and approvals of all individuals engaged by an entity with immediate effect by written notice to the entity. The notice will specify the reasons for the suspension and the period of suspension and invite the entity to explain in writing why the access should not be suspended. All permits, access cards, and approvals held by that entity must be surrendered within 72 hours of the notice.
- 18.2.3 At any time during the period of suspension, QAC may:
- (a) Lift the suspension.
 - (b) Extend the period of suspension.
 - (c) Withdraw the permits, access cards, and approvals per these regulations.
- 18.2.4 At any time during the period of suspension, QAC may withdraw an entity's permits, access cards, and approvals of employees by providing written notice to that entity. The notice will specify the reasons for the withdrawal and invite the entity to explain in writing why the access should be reinstated.
- 18.2.5 If no explanation has been received from the entity within 7 days, the access cards will be immediately withdrawn. If QAC is unsatisfied with the explanation, it may withdraw access at its discretion.
- 18.2.6 An entity may appeal a withdrawal decision, in writing, to the QAC Head of Operations, Safety & Compliance, who will follow the procedure set out for individual appeals in clause 8.8.
- 18.2.7 For the avoidance of doubt, nothing inhibits QAC's authority to restrict access to individuals (despite their employment arrangements), following other provisions in these regulations.

18.3 Penalties Tables

Aviation Security		
Code	Offence	Points
1001	Tailgating through access-controlled door	4
1002	Allowing tailgating or opening a secure door for an unauthorised person to enter/exit	6
1003	Bypassing the screening process to a sterile area	6
1004	Leaving escort required personnel under your supervision airside without escort	6
1005	In a secure area or security-enhanced area for any reason other than the purpose of your duties	4
1006	Lending AIC/APC to another person to access any part of the airport	6
1007	Leaving 'tools of the trade' unattended in a security-enhanced area	6
1009	Leaving any item within 1.5 meters of a security fence	4
1010	Leaving bag(s) or item(s) unattended	4
1011	Making inappropriate comments about security threats (for example, but not limited to a bomb or hijack)	6
1012	Tampering with or damaging security equipment	12
1013	Leaving access-controlled door or security gate unlocked or open while unattended	6
1014	Failing to display AIC on the outermost part of the garment	4
1015	Failing to properly secure a security gate or access-controlled door	4
1016	In a security area or security-enhanced area without a valid AIC	6

Border Security		
Code	Offence	Points
2101	In Biosecurity or Customs controlled areas for any reason other than the purpose of your duties	4
2102	Consuming food or drink in a Biosecurity controlled area	4
2103	Bypassing Customs, MPI or Immigration assessment/vetting processes with risk goods, items from BCA or international aircraft	12
2104	Removing items from amnesty bins	6
2105	Leaving international waste from BCA or international aircraft on the floor or outside of a biosecurity waste bin	4
2106	Not fully closing a biosecurity waste bin lid	4
2107	Failing to double bag or sealing bins bags for biosecurity waste	4
2108	Disposing of items in amnesty waste bins	4
2109	Placing bags on any belt other than the allocated	4
2110	Placing international bags on the domestic belt	6
2111	Devanning international bags without the supervision of an MPI accredited person	6
2112	An accredited person failing to supervise the devanning of international and/or correctly clear international airicans on completion	6
2113	Failing to correctly notify MPI of contaminants found	6
2114	Failing to notify MPI and Customs of Medical on international arriving aircraft	4
2115	Failing to comply with disinsection requirements	4
2116	Failure to set up international walkways	6
2117	Allowing international passengers to deboard before walkway checks and international arrivals sheet complete	6
2118	Failure to supervise and/or control international arriving passengers	6
2119	Physical contact with international arriving passengers for any reason other than work purposes	4

[PRINTED COPIES ARE UNCONTROLLED]

Driving		
Code	Offence	Points
3000	Failure to follow the direction of a QAC authorised officer	6
3001	Failure to show ADP or AIC when requested by an authorised officer	6
3002	Failure to produce New Zealand Drivers or international equivalent License within 72 hours of a request by an authorised officer	4
3003	Failure to hold a valid AVP	4
3004	Failure to display a valid AVP	4
3005	Failure to maintain a vehicle in a good state of repair	4
3006	Driving with an expired ADP	4
3007	Failure to wear a seatbelt where a seatbelt is fitted	4
3008	Driving in a Category 2 or 3 ADP zone without appropriate ADP	12
3009	Failure to stop at a stop sign or stop line	4
3100	Failure to give way at a give way sign	4
3101	Disobeying traffic directions or signals	4
3102	Using a hand-held telephone while driving airside	4
3103	Knowingly dropping debris from a vehicle airside	6
3104	Failure to secure a load on a vehicle or trailer	4
3105	Failure to give way to passengers or pedestrians at a pedestrian crossing	4
3106	Driving across a passenger or pedestrian walkway during loading/unloading of passengers	4
3107	Failure to display company logos/identification on vehicle	4
3108	Failure to use rotating beacons in the manoeuvring area	4
3109	Carrying a passenger when there is no seat provided - Driver	6
3110	Riding on a vehicle without a seat	4
3111	Exceeding the speed limit by up to 20 km/h	4
3112	Exceeding the speed limit by more than 20 km/h but not more than 30 km/h	6

[PRINTED COPIES ARE UNCONTROLLED]

3113	Exceeding the speed limit by more than 30 km/h	12
3114	Failure to give way to aircraft taxiing or under tow/push	6
3115	Failure to overtake in a safe manner	4
3116	Driving in a manner dangerous to people	12
3117	Failure to give way to other vehicles on airside roadways	4
3118	Towing more than the allowable number of rolling stock	4
3119	Access an area without lawful reason or excuse	4
3120	Failure to comply with ATC instruction	6
3121	Failure to dip headlights on manoeuvring area between hours of sunset and sunrise or during declared low visibility	4
3122	Driving without headlights	4
3123	Parking in an area that obstructs aircraft, pedestrians, or vehicles	4
3124	Failure to park wholly within a designated storage or staging area	4
3125	Parking a fuel vehicle/dispenser within 15m from any terminal building	6
3126	Parking in areas that are designated by signs or markings as no parking areas	4
3127	Providing an escort without ADP endorsement	4
3128	Failure to comply with escorting rules while escorting	4
3129	Reckless driving or driving in a manner dangerous to vehicles or equipment	6
3130	Driving a vehicle within 5 meters on a parked aircraft without requirement	4
3131	Walking or driving behind aircraft while anti-collision lights activated	6
3132	Failure to comply with the Circle of Safety Rule	4
3133	Driving between aircraft engines or under any fuselage or wings when vehicle not approved for the aircraft type	4
3134	Failure to maintain required clearances from operating aircraft	6
3135	Failure to stop after an accident	6
3137	Failure to give information or giving false or misleading information	4
3138	Failure to stop when requested by an authorised officer	6
3139	Cutting across apron stands	4

[PRINTED COPIES ARE UNCONTROLLED]

3140	Entering reclaim with 5 or more cans	4
3141	Parking a vehicle or equipment over a fire hydrant	4
3142	Careless Driving	4
3143	Parking in a prohibited area	4

General Health and Safety		
Code	Offence	Points
4000	Not wearing required PPE or high-visibility clothing when required	4
4001	Working under the influence of drugs or alcohol	12
4002		
4003	Not using designated crossing points when crossing roads	4
4004	Acting in an aggressive or threatening manner	6
4005	Causing physical harm to any person(s)	12
4006	Failing to follow instructions of QAC operations or approved officer	6
4007	Smoking while airside	6
4008	Smoking landside other than in a designated area	4
4009	Dropping litter or other FOD	4
4100	Operating a portable electronic device within 6 meters of an aircraft fuel point, fuel vent or other fuelling equipment	4
4101	Consuming alcohol or any illegal or prohibited substance airside	12
4102	Riding a bike, skateboard, or similar device airside without authority	4
4103	Entering a security area or security enhanced area without the required clearance or required competencies	6
4104	Entering a leased area airside without approval of the lessee or QAC	4
4105	Entering an unserviceable or works area without an operational need	4
4106	Driving without an ADP in a Category 1 area	6

[PRINTED COPIES ARE UNCONTROLLED]

4107	Driving in a Category 2 or Category 3 area without an ADP	12
4108	Driving airside with a suspended or withdrawn ADP	12
4109	Failure to report an accident or incident within 24 hours	4
4110	Failure to properly secure equipment against adverse weather conditions	6
4111	Failure to secure an animal airside	6
4112	Failing to correctly inform or control escorted person(s) while escorting	4
4113	Looking after a bag(s) or item(s) for an unknown person	4
4114	Entering the Manoeuvring Area without ATC clearance	12
4115	Failure to setup domestic walkways	4

19.1 ADP Category Zones

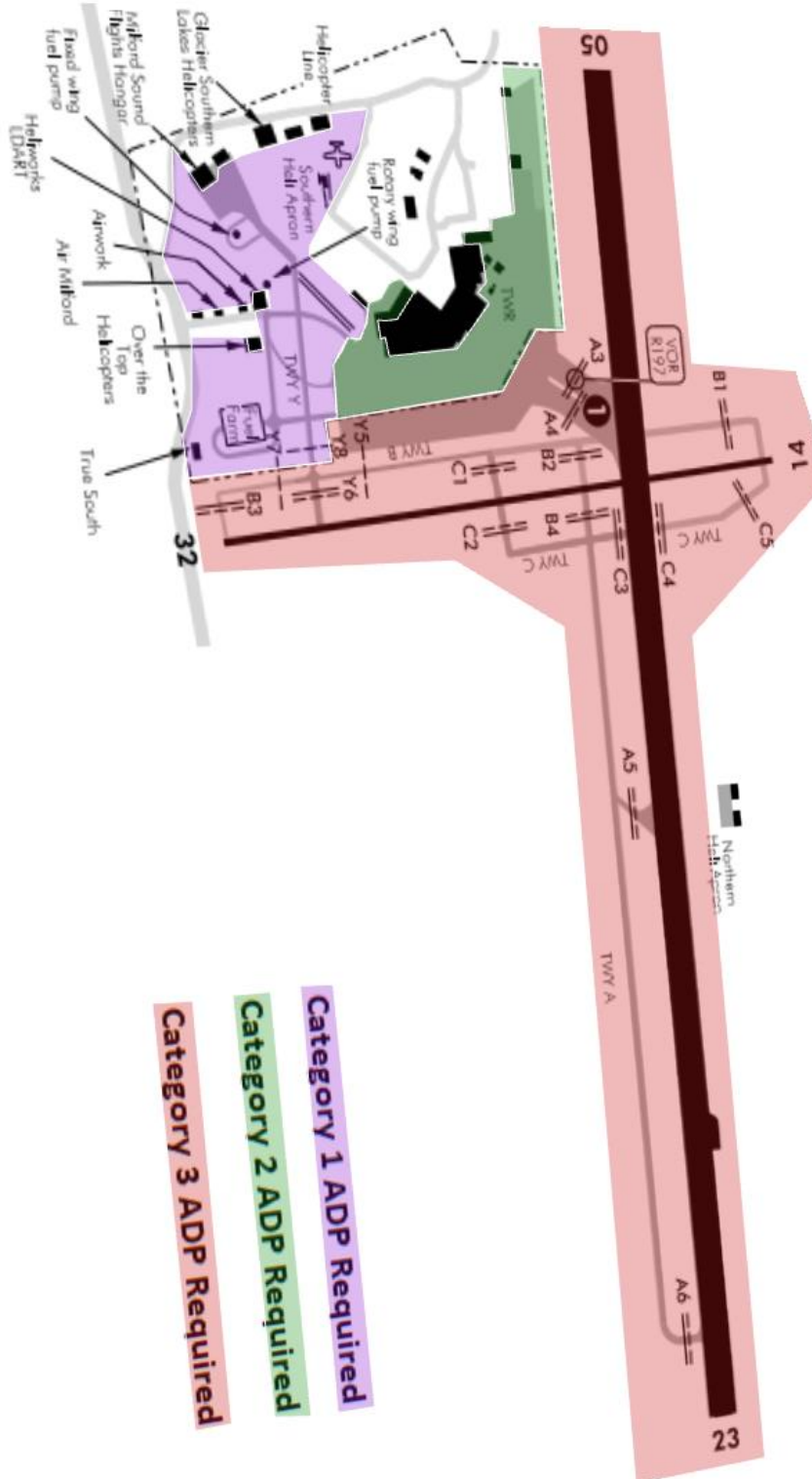

19.2 Work Zones Chart

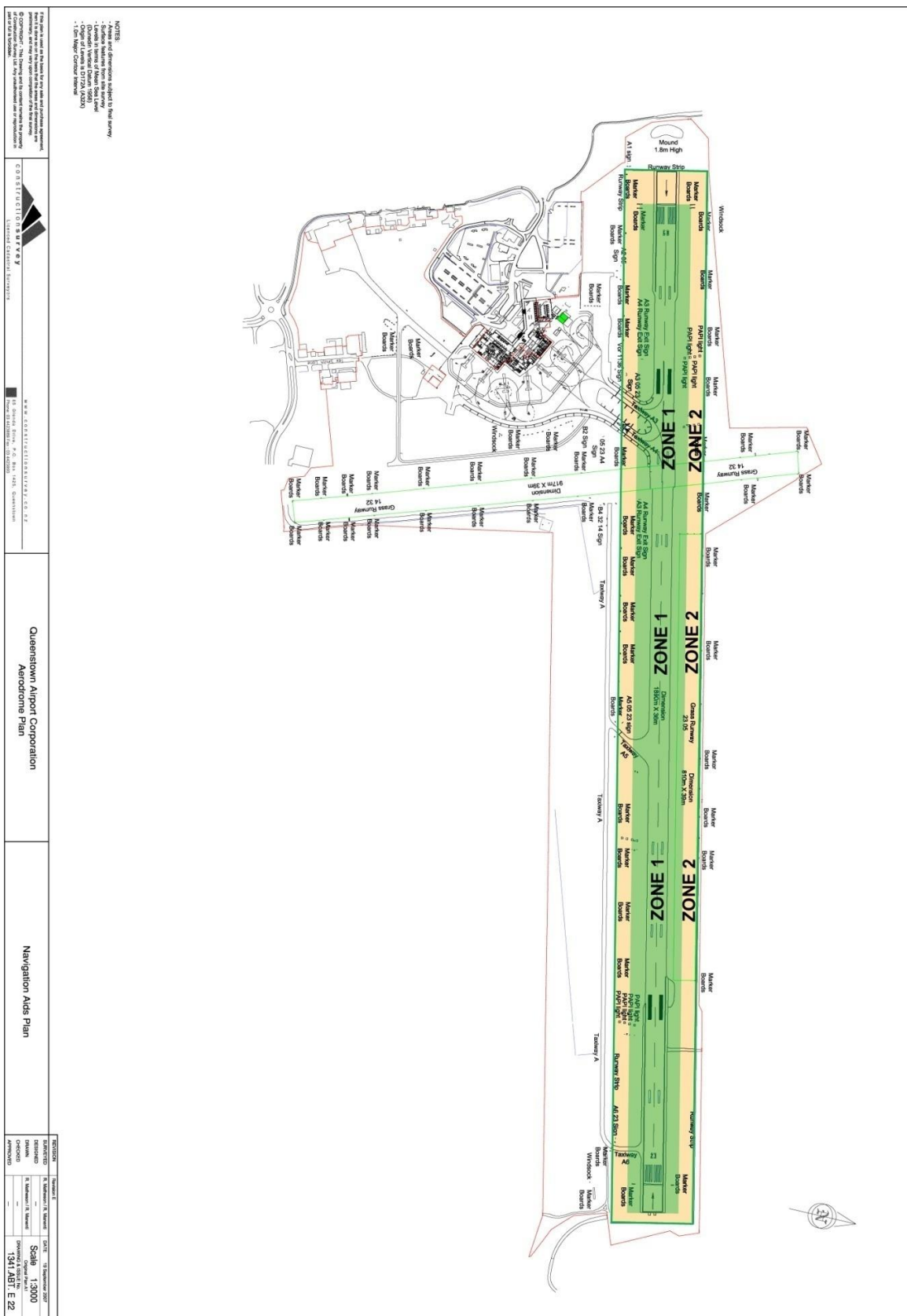

19.3 Aerodrome Grid Chart

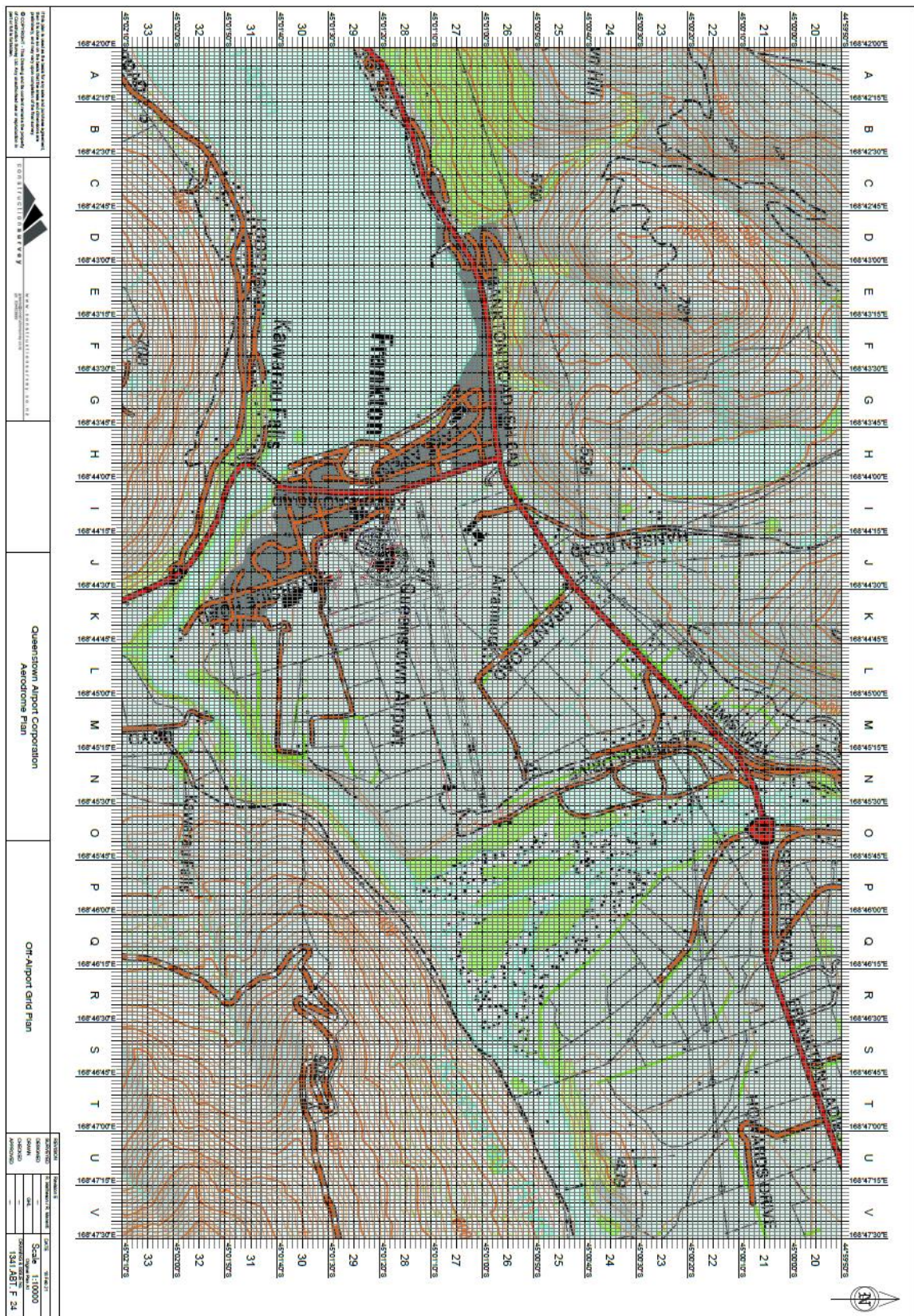

Copyright ©2009 by Queenstown Airport Corporation Ltd. Reproduction of this manual, or any part thereof is prohibited except with the approval from Queenstown Airport Corporation.

VERSION QASCR-3.2 EXP: 31/12/2025

QUEENSTOWN AERODROME SAFETY AND COMPLIANCE REGULATIONS

19.4 Ground Movement Charts (AIPNZ)

THESE PAGES ARE NOT FOR AIR NAVIGATION

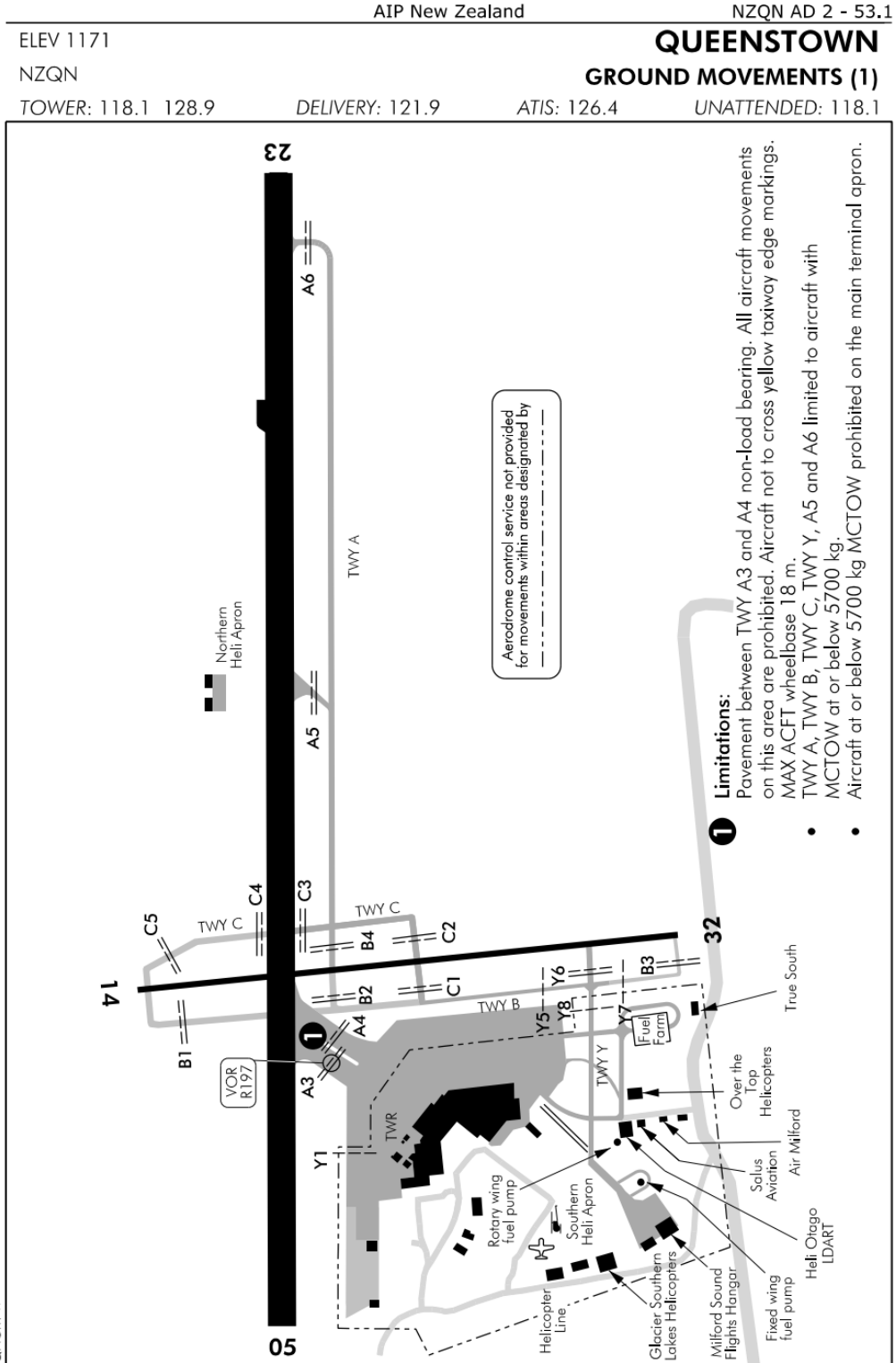

**QUEENSTOWN
GROUND MOVEMENTS (2)**

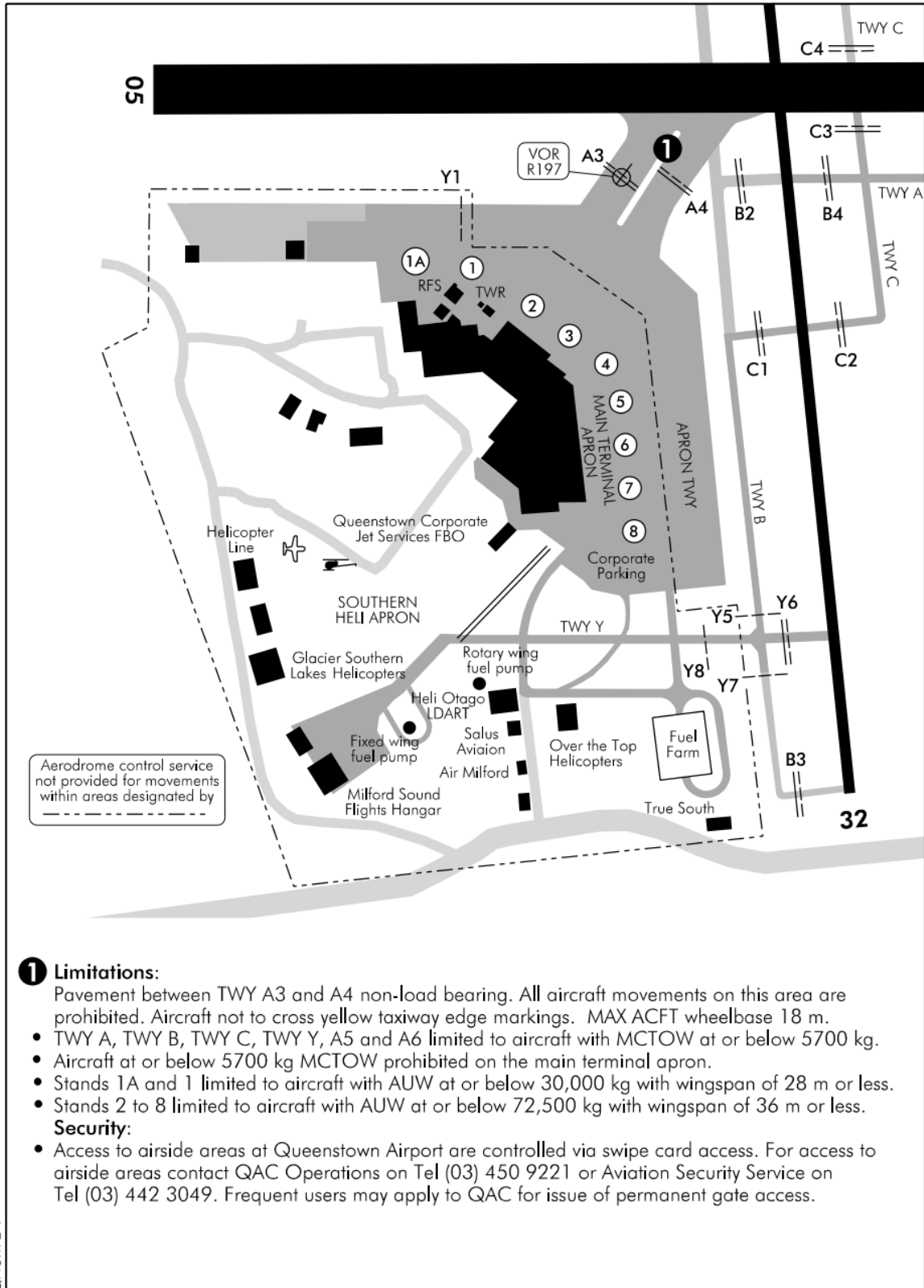

19.5 Stop Block Markers



Accident	An occurrence in which any person suffers death or serious injury and/or an aircraft, facility building, or piece of equipment sustains damage.
Aerodrome Emergency Plan (AEP)	A plan developed by the airport operator to coordinate all agencies and their individual aerodrome emergency procedures.
Aerodrome Works	Any construction of maintenance works carried out on or adjacent to the movement area that may create obstacles or restricted the normal movement of aircraft.
Aeronautical Information Publication New Zealand (AIPNZ)	Means the AIP for New Zealand published under the authority of CAA by Airways New Zealand.
Aeroplane	Means a power-driven heavier than air aircraft deriving its lift in flight chiefly from aerodynamic reaction on surfaces which remain fixed under given conditions of flight.
Air Traffic Control (ATC)	A general term about the exercise of control over vehicle and aircraft at Queenstown Airport by Airways New Zealand.
Air Traffic Services (ATS)	Mean a unit providing an air traffic service, which may include an air traffic control unit and a flight information centre.
Aircraft	Means any machine that can derive support in the atmosphere from the reactions of the air otherwise by the reactions of the air against the surface of the earth.
Airport	Queenstown Airport (NZQN/ZQN).
Airport Identity Card (AIC)	An identification card issued by the Aviation Security Service
Escort Required Airport Identity Card	Temporary identification issued by the Aviation Security Service with a requirement to be always escorted by an AIC holder while airside.
Airside	That part of the airport designated as a security area or security enhanced area and to which the public does not have free access.
ARFF	Airport Rescue and Fire Fighting Service owned and operated by QAC.
Airside Driver Permit (ADP)	An authority issued to a person in accordance with these regulations.
Airport Infringement Notice (AIN)	An infringement notice issued by an authorised person, following a breach of these regulations.
Airside Vehicle Permit (AVP)	An authority issued in accordance with these regulations.
Approved Testing Officer	A person approved by QAC in accordance with these regulations.

[PRINTED COPIES ARE UNCONTROLLED]

Apron	Means an area on the airport intended to accommodate aircraft for the purpose of loading or unloading passengers or cargo refuelling, parking, or maintenance.
Authorised Signatory	A authorised signatory employed by a vehicle operation to sign a request for an AVP/ADP application.
Aviation Security Service	Means the Aviation Security Service established under section 72B (2) (ca) of the Civil Aviation Act 1990.
Backtrack	Taxiing on a runway in the opposite direction to the current direction of operation
CAA	Civil Aviation Authority of New Zealand.
Competency	An authorisation to exercise privileges in a certain area. This includes, but is not limited to, access to security areas, access to biosecurity-controlled areas, ATC clearance, airside driving privileges and identity cards.
Dangerous Driving	Means driving without due care and attention including driving without regard for the safety of aircraft, passengers, and others airside.
Drive Behind	Driving at the rear of and/or within the specified safety area for that aircraft and/or past the aircraft in any way that breaches the driving regulations specified in this manual.
Escort	A person with the required competencies who grants access to another person and/or vehicle airside and has responsibility for them while airside.
Face Covering	Any type of covering that covers the face and mouth of the wearer. (e.g., mask, scarf, or a bandana).
Frequent	At least once a week
Helicopter	a type of aircraft which derives both lift and propulsion from one or more sets of horizontally revolving overhead rotors
Incident	An occurrence, other than an accident, which does or could affect the safety of aircraft, persons, facility, vehicle or equipment.
Landside	That part of the airport not designated as Security Area or Security Enhanced Area and to which the general public has free access.
Leased Area	An area in respect of which a tenant pays a fee under a lease for exclusive use of that area.
Manoeuvring Area	That part of the airport used for the take-off and landing of aircraft and for the surface movement of aircraft associated with take-off and landing, excluding aprons.
Markings	A line, symbol or group of symbols/lines displayed on the surface of the ground to convey information.
Medical Event	An event that requires the attendance of a paramedic, rescue firefighter, or other qualified medical professional
Movement Area	That part of the aerodrome used for surface movement of aircraft, including Aprons and Manoeuvring Areas.

[PRINTED COPIES ARE UNCONTROLLED]

Official Duties	Tasks assigned to an individual by QAC, or by that individual's employer, that are required to be completed by that individual.
Prohibited or Restricted Area	Any part of the airport, designated by legislation or otherwise, access to which is prohibited to persons not having lawful authority or excuse to enter that area.
QAC	Queenstown Airport Corporation Ltd, the operator of the airport.
Queenstown Aerodrome Safety and Compliance Regulations	These regulations issued by QAC.
Runway	Mean a defined rectangular area on the aerodrome prepared for the landing and take-off of aircraft.
Runway/Taxiway Strip	A specific area on each side of the runway/taxiway designed to reduce the risk of damage to aircraft should it run off the runway/taxiway.
Screening Point	Means the fixed area prior to entering the gate lounges where persons are subject to the application of technical or any other means to detect a weapon, explosive, or other dangerous device, article or substance, that may be used to commit an act of unlawful interference
Security Area	Means an area that the Director of Civil Aviation has declared to be a security area under section 84 of the Civil Aviation Act 1990.
Security Enhanced Area	Means an area that the Director of Civil Aviation has declared to be a security enhanced area under section 84 of the Civil Aviation Act 1990.
Speed Limit	The speed limit in a particular area determined in accordance with these regulations.
Stand	A designated area on an apron to be used for parking an aircraft.
Subsidiary	An at least 50% owned subsidiary company.
Supervised Vehicle	A vehicle driver under supervision in accordance with these regulations.
Tailgate	To pass through an access-controlled door or gate by any means other than those permitted by these regulations on the same swipe/pin as another person
Transitional Facility	Means any place approved as a transitional facility in accordance with section 39 of the Biosecurity Act 1993 for the purpose of inspection, storage, treatment, quarantine, holding, or destruction of uncleared goods or a part of a port declared to be a transitional facility in accordance with section 39 of the Biosecurity Act 1993.
Vehicle	A motor vehicle or other specialised Airside mobile plant or equipment other than unicycles, bicycles, tricycles and skateboards.

[PRINTED COPIES ARE UNCONTROLLED]

Vehicle Operator	A person, firm, body corporate, or Government Agency controlling the operating of a vehicle whether as owner, hirer or otherwise.
Work Purposes	Forming a part of that person's duties as reasonably required by their employer.